

A modern, clean dental clinic with a large skylight and dental equipment. The room is bright and airy, featuring white cabinetry, a long counter with a sink, and a dental chair. The ceiling has a large skylight and recessed lighting. The overall aesthetic is professional and minimalist.

# Clean & Medical Lighting

LUXIONA

EN

# Index

2	Our values
4	Competitive manufacturing
6	LUXIONA Clean room manufacturing
8	Lighting Consulting
9	Sustainable solutions. Innovative technology
10	Customise and go beyond the standards
28	From extreme to standard clean requirements
36	UVC disinfection lighting
42	Hospital lighting solutions for every space
46	Clean manufactory solutions for every space
88	Selection of luminaires for hospitals
91	Selection of luminaires for clean manufactory
98	Chosen projects for Clean & Medical around the world
100	LUXIONA worldwide

# Design Customisation Competitiveness

# Our values

## Design

At LUXIONA, design is at the heart of our identity. With products designed in Barcelona and developed in Poland, we combine European creativity and engineering excellence. Our portfolio covers a complete range of functional lighting solutions that are functional, easy to integrate, and simple to maintain—always with a focus on human comfort, both physiological and psychological.

## Customisation

We create lighting that adapts to every project. From unique solutions that differentiate spaces to flexible development supported by our European factory, we provide tailored consultancy and agile response. This ensures solutions that address specific functional needs while meeting project requirements in the shortest possible time.

## Competitiveness

Our competitiveness lies in delivering value without compromise. We combine proximity and service with high technical performance, delivering the best balance between quality and value. With more than a century of expertise and state-of-the-art innovation, we develop energy-efficient and sustainable solutions designed to perform today and endure tomorrow.



**DESIGN PLUS**



LUXIONA Main Factory, Jacentow. Poland

## Competitive manufacturing

By combining design in Barcelona with production in Europe, LUXIONA provides customers with competitive, flexible and timely solutions.

A certified production plant for clean and medical luminaires and logistics centre located in Poland allows us to be independent and offer fast turnaround times, as well as better communication and advice. Our infrastructure and technical equipment are constantly updated to offer continuous improvement of production. With our on-site

certified clean room we are one of the few manufacturers in Europe in full control of the production process, while maintaining the necessary standards to certify our luminaires for installations requiring a high degree of cleanliness atmosphere, including ISO 14644-1 certification for clean rooms.

As a result, our product range covers different sectors: architectural, office, industrial, sports, retail, clean rooms, medical and hospital facilities, as well as for the pharmaceutical, chemical, food and electronics industries.



LUXIONA Main Factory, Jacentow. Poland

ISO  
13485

## Clean and medical ISO 13485 certified factory in Jacentow

LUXIONA's production plant is fully equipped with technologies enabling us to disinfect and prepare the luminaires according to ISO standards. Our production process requires not only the highest standards but also a broad machinery park and separate rooms dedicated to manufacturing clean and medical products.

The experience gathered through years combined with the development of modern solutions results in a wide variety of products. We are also able to provide short realisation terms, thanks to independence from external factors and the complexity of our technologies that ensure the flexibility of our production process.

Certificate  
ISO 14001:2015



Certificate  
ISO 9001:2015



Certificate  
HACCP



Certificate  
ISO 13485:2016





LUXIONA Main Factory, Jacentow. Poland





# LUXIONA Clean room manufacturing

**Cleanroom technology offers a broad range of solutions, creating an atmosphere as sterile as possible. To achieve the safety and best results both in medical facilities and in industries it is important to ensure the correct clean room conditions.**

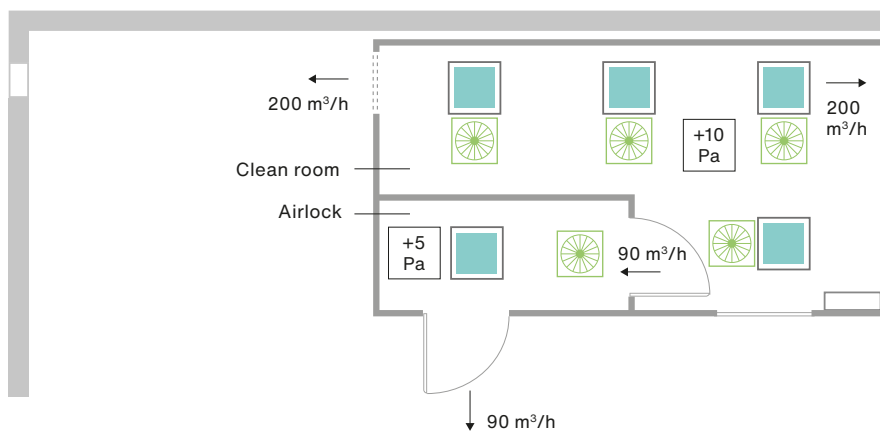

Used in a wide variety of manufacturing areas clean room technology is present from chemistry, pharmaceuticals through precision engineering and microelectronics, biological laboratories and food industry. All these different applications involve a wide range of different tasks: from illuminating a patient recovery room or operating theatre to high illuminance levels in laboratories, a range of applications in terms of specific industry requirements is diverse. In all cases the pollution by particles classified as contamination is strictly controlled: no matter how small they are, the number of airborne dust particles, bacteria, viruses, and chemical vapours must be as small as possible.

The purpose of clean-room technology is to protect patients and processes as well as manufactured products against contamination of any sort. The contamination is strictly monitored even in the clean room premises that have dimensions of a production hall and a surface of a few thousand square meters. These kinds of premises are commonly used during the production process of precise semiconductors, biotechnology, and other fields in which even tiny pollution is a critical parameter of technology.

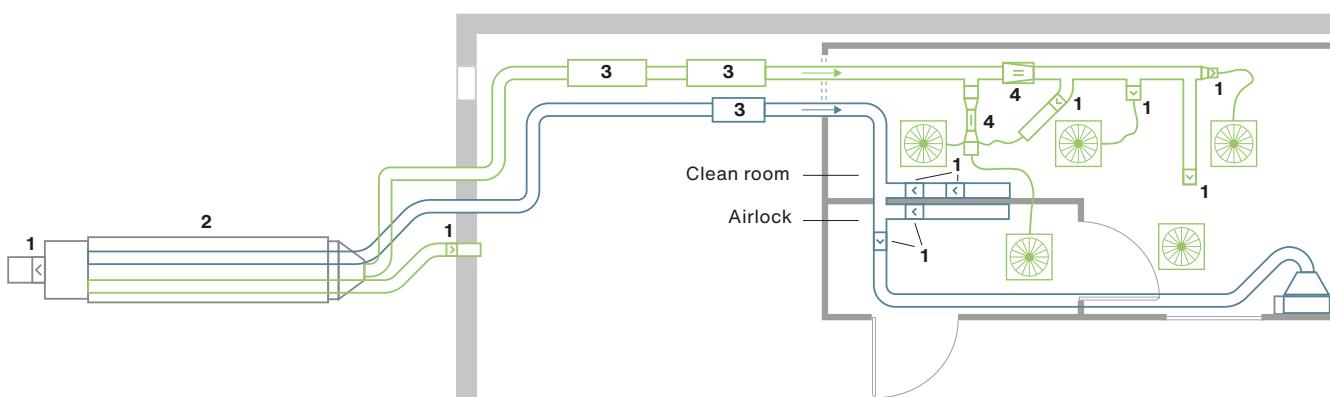

-  Lighting luminaire Agat Clean No Frame
-  Swirl diffuser with H13 air filter (air volumes up to 375 m³/h)
-  +5 Pa Overpressure in the room
-  200 m³/h Air flow through the crevice in the door and through process holes



-  Air diffusion
-  Air return
-  Flexible pipe
- 1. Regulating damper
- 2. Air handling system: diffusion, indoor, hygienic
- 3. Air duct noise silencer
- 4. Constant air volume regulator

## Our clean room technology

In our clean room manufacturing premises the air is pumped inside the clean room through a special system of filters which eliminate subsequent fractions of pollution. The air inside the room is continuously filtered by a set of HEPA filters in order to remove the pollution created inside. The employees entering and exiting the room have to do it through the airlock. The employees inside the clean room should wear all

the time protective suits, masks, and shoes. In less expensive solutions there is no air lock-the entrance is directly from the antechamber where a protective suit is worn. The devices inside a clean room have to be specially designed so as not to generate additional pollution. It applies also to luminaires which are produced in our production plant in specially prepared conditions.

# Lighting Consulting

**Our team of 50+ experts is always available in each country of our presence and will support you in your lighting projects. We provide personalised, industry-specific advice based on experience and the know-how we have gained throughout the years. By fully monitoring your project through to implementation, we offer you a global and integral vision at every stage. A personal approach to every client is at the centre of our work and leads to a partnerships that result in top-quality projects.**



## **Customer and project requirements**

Stage 1: Plan including (suggestions for) the placement of luminaires. Detailed plans with sections, cuts, ceiling types, and furnishings. Functions, branding, ambience, experience, sensations, levels, and creation of environments. BIM methodology.



## **Lighting consulting, conceptualisation and development of the project Analysis and review of your plans and needs**

Stage 2: Concept sketch of the lighting design. Plans with recommended placement of luminaires. Lighting design and calculations (3D modelling). Calculations to adjust and approve the (final) lighting design and the lighting levels, sensations, consumption control, and efficiency. Development of special projects and products.



## **Presentation and delivery of the project**

Stage 3: Lighting levels represented in false colours. Luminaire placement plan (PDF and CAD). Technical data sheets of the applied products. Control and Smart Lighting services: Creation of groups and scenes, location of sensors, sketches and electrical diagrams, configuration, etc.



## **Technical support and customer service**

Stage 4: The final lighting simulation project. Follow-up and supervision of installation and configurations. Incident management. Maintenance and repairs. Programming and commissioning of regulation and control systems.

# Sustainable solutions

Sustainability is at the very core of responsible businesses. By working together we strive to develop projects that have a positive impact on the environment and promote sustainable lighting so important for modern facilities in the clean room industries, where efficiency and energy-saving is one of the most crucial factors. We are able to achieve this by using intelligent switching control systems and by providing users with efficient, and sustainable solutions.

One of them are LED sources used in LUXIONA luminaires, characterised by a long lifespan of 100,000 h and the LxBy parameter at the L80B10 level. This means that after 100,000 hours of use, the LED sources will retain 80% of their initial luminous flux, and only 10% of the LEDs will have less than 80% of their initial luminous flux. This means that we can enjoy their quality longer.

# Innovative technology

Innovations and functionality have always been and will remain an important factor in the development of new lighting solutions, services, and the application of new technologies. The know-how accumulated after almost half a century of experience and the combination of design and engineering allows us to stay one step ahead.

Together with our R+D+i department, in constant search for new lighting solutions, we are able to use the latest generation of materials and production processes. Looking to the future combined with our experience allow us to shape the lighting of the future and expand our innovative product portfolio.



## Certification programmes for green buildings



# **Customise and go beyond the standards**

**We leave nothing to chance. By listening, understanding, and combining our knowledge and experience we make the most of available possibilities. By anticipating the specific needs of investors, architects and designers especially focused on the clean room projects we are able to meet all the requirements of every project.**

**The wide range of customisable solutions has a number of applications specifically developed by our experts to meet demanding needs of clean room both in medical facilities and in industries requiring a high degree of cleanliness of the atmosphere.**



## Light

### Colour temperature

From warm to cool, reproduces the colour of natural light to help recovering patients restore their natural sleep and awake biorythm.

### Colour rendering

Reproduces the real colours of an object. In medical facilities, the correct rendering of the skin and blood colour is crucial.

### Lumen

The amount of visual light emitted is especially important in medical applications where high trough-puts are needed in critical areas such as surgery.

### Diffuser

Gives a wide choice to control the emission and protect the fitting against the dust and moisture, especially important in industry requiring high level of cleanliness.

### Optic

The way the light is directed, implies managing reflections to have most of light where is needed whilst not disturbing patients in bed units. Also it is very important to correct with the help of optics, directing the light where appropriate, in such rooms where the designer cannot freely place luminaires due to normative constraints.

### Emission

Optimising light output to achieve best performance comfort and wellness. Direct, undirect and Up&Down.



## Gear

### Control

On/off, dim light on request.

### Endurance

Adapt lifespan to project needs even in hard conditions.

### Emergency

Safety by lighting even when there is no electrical supply.

### Sensors

Interaction in realtime between lighting and application environment.



## Body

### Size

Dimension adjusted to specific project.

### Material

Sheet steel, stainless steel  
Protection: IP, IK.

### Finishing

Standard RAL 9016 white colour, any other RAL colour on request. Coloured luminaires are particularly recommended for children's wards in hospitals. Special luminaires coatings: antibacterial - crucial for high degree cleanliness rooms and anti-reflective - recommended for operating theaters where a laser light beam is used.

### Installation

Installation in suspended ceilings with modular structure, in plasterboard ceilings, directly on the fixed ceiling or on the wall. Luminaires can be adapted to different types of ceilings with different module sizes. Suitable for installation in technical ceilings where lighting maintenance can be carried out directly without entering the room, which is particularly important in clean rooms.

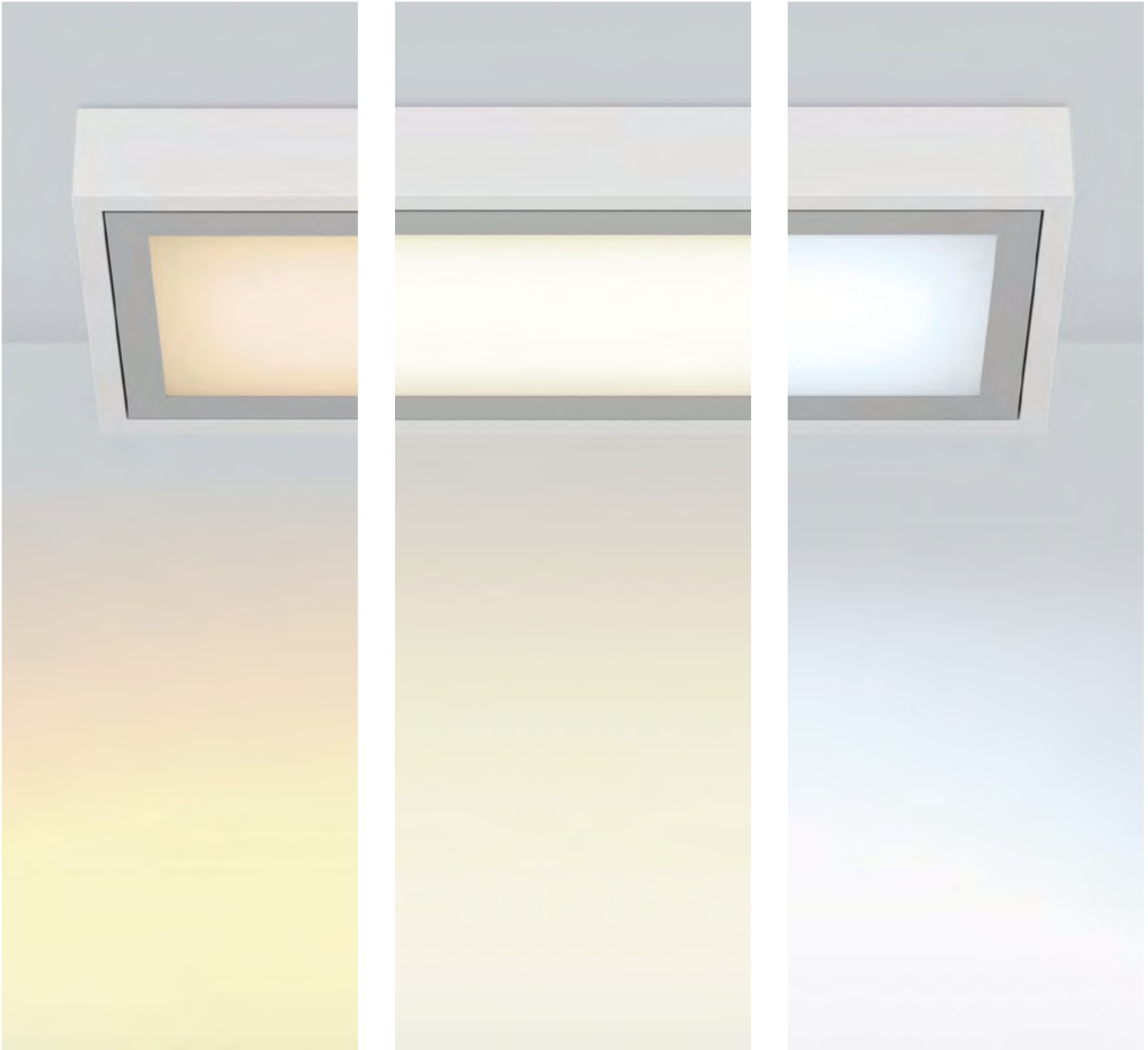

## Tunable White

An increasing number of scientific studies confirm the effects of light on different areas of our lives. The intensity of light and its spectrum plays also a very important role in both our physical and mental wellbeing. In order to ensure the right intensity of light and right colour temperature of artificial light, and also aligning it with the natural light at a given time of day, Tunable White is a perfect solution. This technology is available

in LUXIONA luminaires and LED modules installed in Clean luminaires, which brings Human Centric Lighting solutions to clean, and medical rooms. The use of technology allows to follow natural circadian rhythm. Well adjusted lighting to specific needs helps patients restore their natural biorhythm thanks to suppressing or increasing production of melatonin. Correct lighting is also crucial for medical staff to stay alert and focused during long shifts.

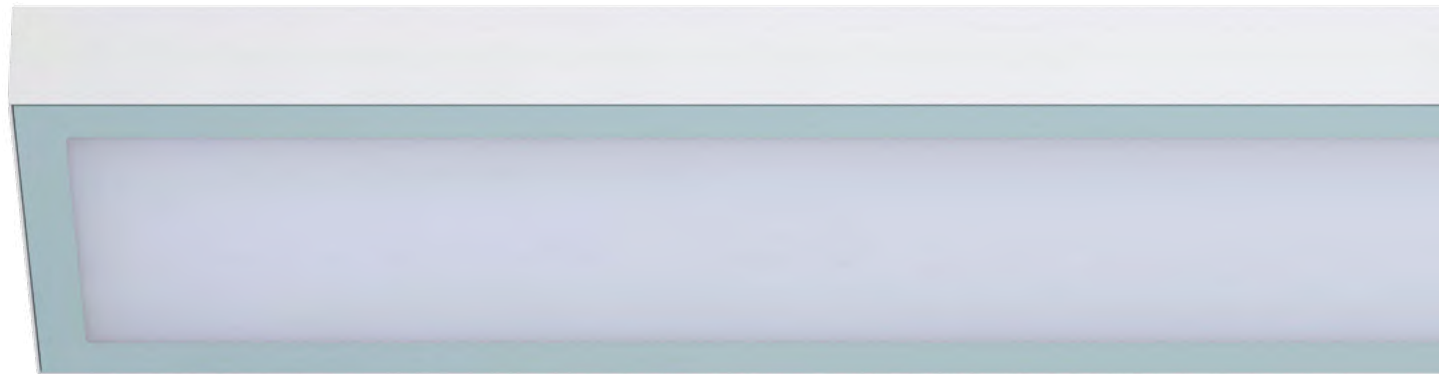

Rubin Clean No Frame



## Exceeding lighting standards

**Adjust the luminaire's luminous flux to achieve the ideal light intensity and its uniformity. Select the luminaire with the appropriate light distribution to easily meet the required lighting standards.**

Correct beam angle will help achieve the appropriate level of average illuminance and its uniformity by using luminaires with lower energy consumption. The right optical control provides comfort for optimal conditions in spacious production halls in the pharmaceutical, electronic, chemical and food industries. This means savings for the investor when

purchasing luminaires as well as lowering the cost of operating the lighting. Correct optical system allows reducing glare, to meet the required standards for specific medical or industrial facilities. To achieve this, choose a product with Micro-PRM or a luminaire with an anti-glare louver.



## Colour rendering index (CRI)

### Competitive lighting solutions with the highest colour rendering index.

LUXIONA is one of the few manufactories in Europe to achieve a CRI>95 for its luminaires (with a high value of the R9 and R13 component, perfectly reflecting the colour of tissue and blood). The luminaire is recommended for operating theatres, where the lighting used should ideally reflect the colours of skin, blood and tissues (high R9 - responsible for rendering 'deep red' and R13 - responsible for rendering 'light orange'). CRI and its definition has to do with the concept of the 'standard observer' and the way the human eye sees colours. To establish that a table of 14 TCS (Test Colour Samples) was created. These colours, designated as TCS1 to TCS14 are

illuminated with test light. This way it's possible to determine the extent to which the light reflected from the test colours is similar to the reflection of the reference light. This produces colour-rendering coefficients R1 to R14, which represent the respective colours TCS1 to TCS14. These coefficients can also be calculated from the spectral characteristics of the light source. For a reference light, the coefficients R1 to R14 are equal to 100. The greater the difference between the reflectance of the test light and that of the reference light for a particular TCS colour, the smaller the corresponding coefficient.



CRI 98,2	LUXIONA's modules and simultaneous preservation of high components
R9	responsible for rendering "deep red" colour (colour of blood)
R13	responsible for rendering "light orange" (colour of tissues)

CCT	3926K
CRI	98,2
λp	642 nm
PFlicker	1,15%



## Clean luminaire CRI95 medical device

### Legal requirements

LUXIONA medical device luminaires are registered in the Office for Registration of Medicinal Products, Medical Devices and Biocidal Products. Luminaires are compatible with requirements defined in directives of European Union: Directive of the Council 93/42/EEC (MDD), the Directive of European Parliament and the Council 2007/47/EC. Our clean luminaire - medical device fulfils also the requirements defined in the bill of February 3rd 2017 about Medical Products. Products are tested and compatible with European norm PN-EN 60601-1, PN-EN 60601-1-2, concerning medical electric devices- overall safety requirements and basic technical requirements.

### Production process

Our certified luminaires - medical devices, require specially dedicated technological line and individual production process, that ensures

the conformity of the products during the design process and production with all requirements. They concern among other things the safety of the products and hazards related to product usage. The production technology is also under restrictive procedures of high quality control, provided by the Office for Registration of Medicinal Products, Medical Devices and Biocidal Products. The quality control includes all stages- from the design and manufacturing of medical product till the moment when the luminaire is placed on the market or used.

### Application

Luminaire is destined for use in:

1. Operating rooms
2. Intensive medical care rooms
3. Rooms dedicated for laparoscopic and endoscopic treatments
4. Recovery rooms
5. Dermatological clinics
6. Blood sampling points

### Product characteristics

1. Anti-reflective C56 which minimalises the reflection of the laser light beam on request.
2. Laminated matt pane with anti-reflective coating-SLMR.
3. Hardened matt pane with anti-reflective coating-SHMR.
4. Micro-prismatic diffuser with laminated anti-reflective pane-Micro PRM SLR.
5. Diffusers resistant to disinfectants, ammonium salt, hydrogen peroxide, chlorine and UV radiation.
6. Laminated matt pane-SLM.
7. Hardened matt pane-SHM.
8. Micro-prismatic diffuser with laminated pane-Micro-PRM SL.
9. Micro-prismatic diffuser with hardened pane-Micro-PRM SH.
10. Antibacterial coating preventing from micro-organisms.
11. Light source of the colour rendering index equal or higher than 95.





## Colours for each clean industry

Matching the LED light sources to the expectations of the project or investor can require luminaires equipped with non-standard light sources, for example with a very warm colour of 2700 K, or with Tunable White light sources or a special colour of LED for specific applications.

### LED of special spectrum for specific applications:

- Green** - laparoscopic surgery
- Yellow** - pharmaceuticals, production of electronic (e.g. microchips)

- Red** - laboratories to observe animals
- Blue** - meat industry
- UV** - disinfection
- Other** - plant cultivation, animal farming, human treatment

Yellow + white  
830/840\*

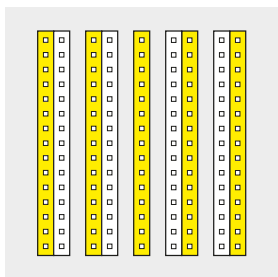

Yellow

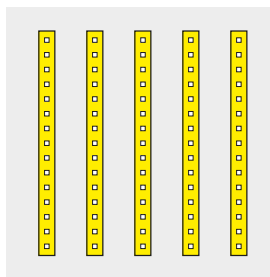

Red + white  
830/840\*

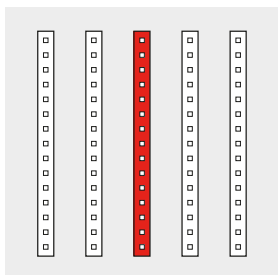

Green + white  
830/840\*

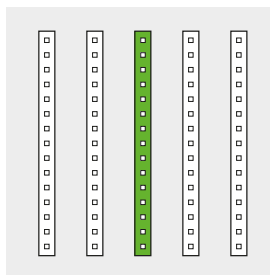

Blue + white  
830/840\*

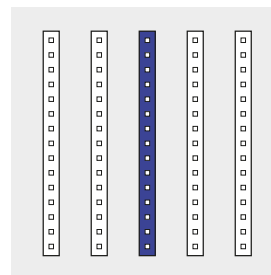

Red + green + blue\*\*

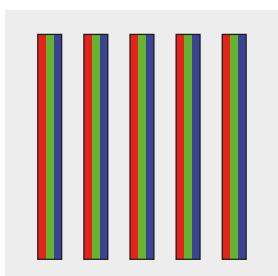

\* Two independent circuits



Hybrid Room at the Provincial Specialist Hospital, Olsztyn. Poland

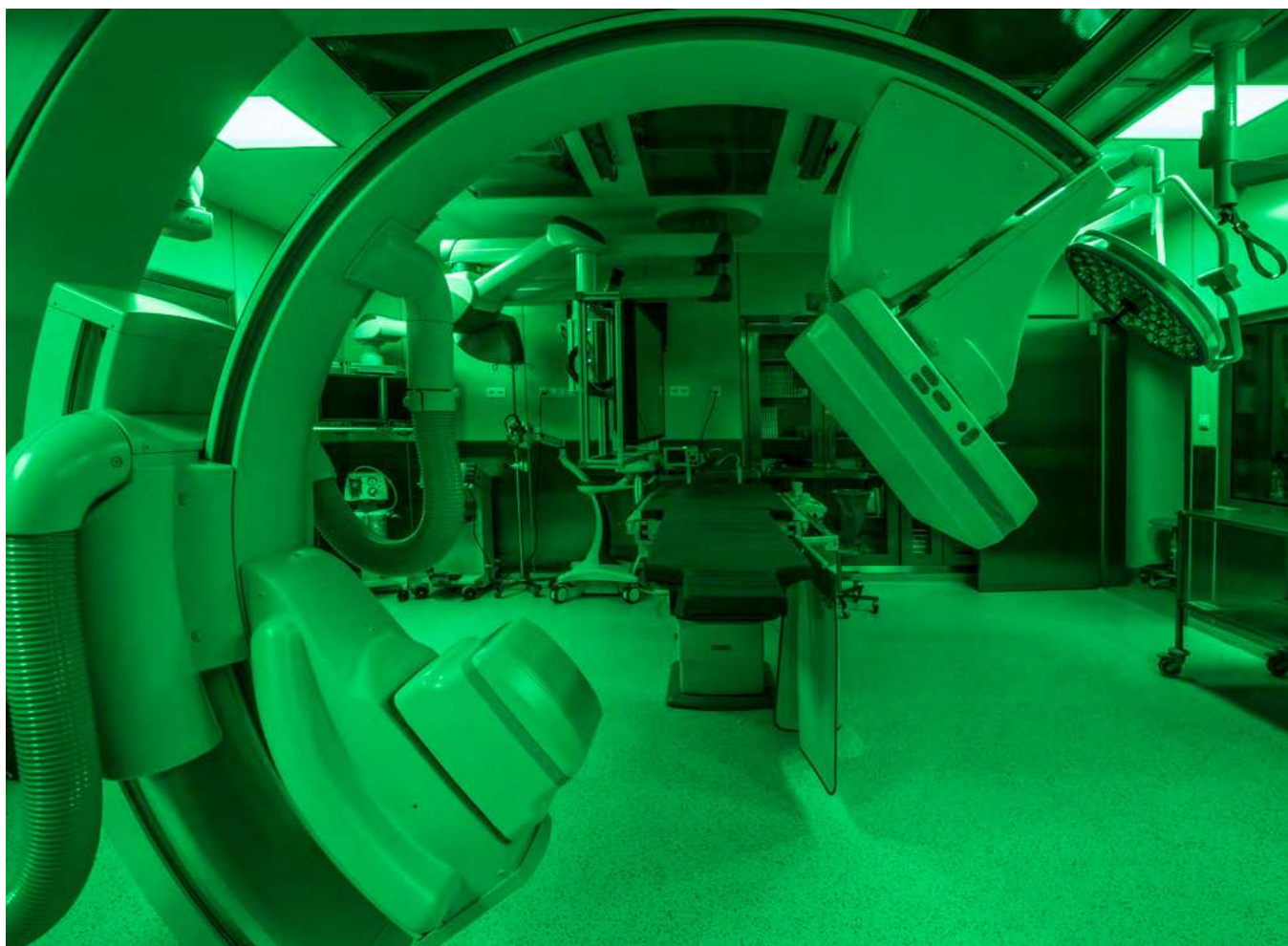

Hybrid Room at the Provincial Specialist Hospital, Olsztyn. Poland 17

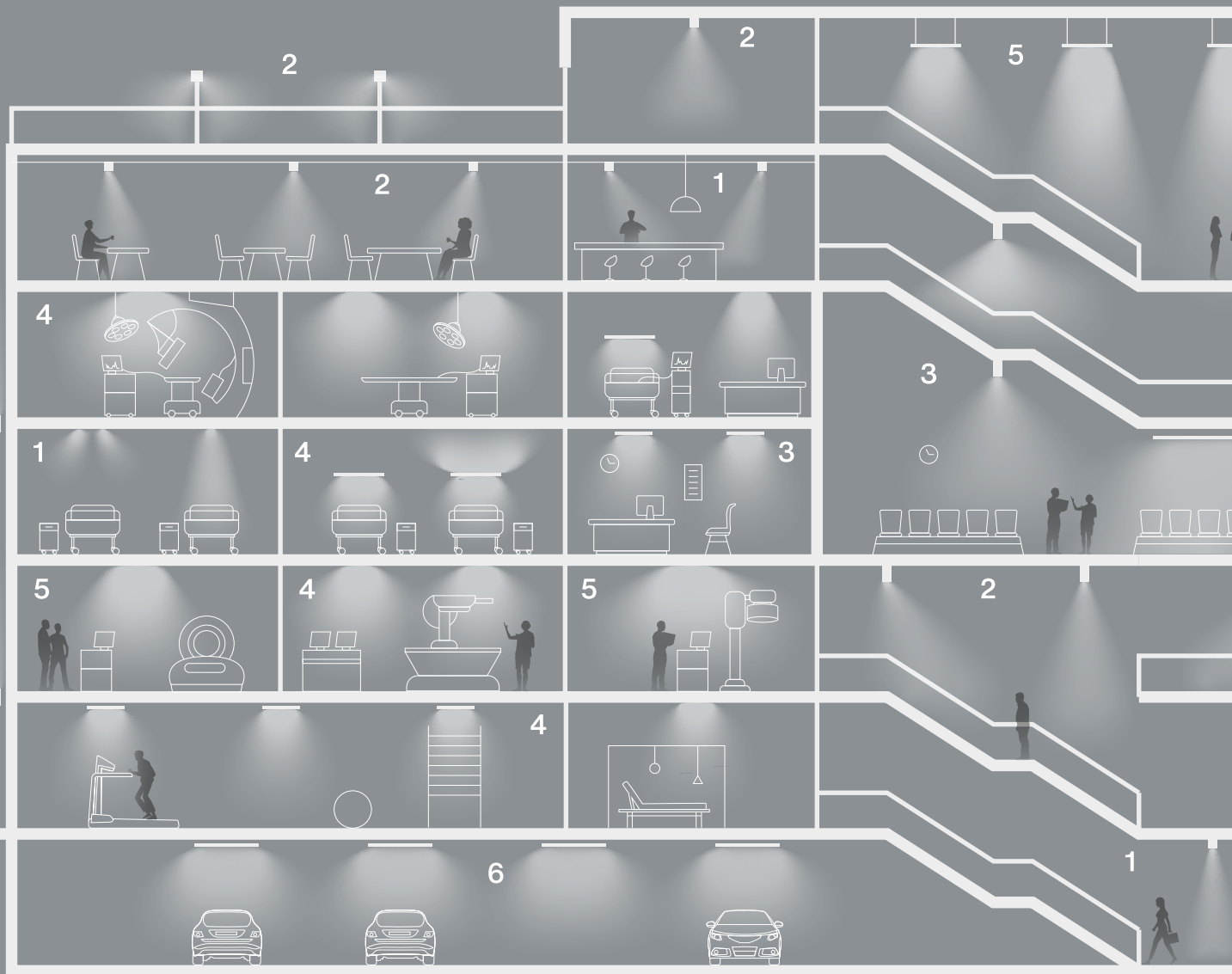

## Solutions tailored to any space

The full availability of product families with customisable optical systems enables a wide variety of light distribution and helps to comply with lighting standards and investor requirements in any clean or medical facilities. We are aware that in some projects standard solutions will not be enough that's why we are open to create new personalised solutions. Our know-how helps us do it regardless of how challenging the project may seem. Choosing functional lighting was never that simple. Starting

from operating theatres - surgery rooms, surroundings of operating theatres, intensive care rooms, blood extraction rooms, patient rooms, common areas: corridors, waiting areas, receptions, underground car parks, and gardens - there are many possibilities to personalise and adjust the solution to a specific medical area or clean industry.

Recessed	Front access for maintenance	Agat
	Rear access for maintenance	Topaz
Surface		Rubin

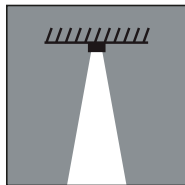

1. narrow spot  
15° up to 35°

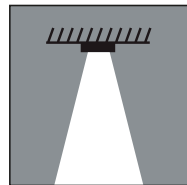

2. medium spot  
30° up to 60°

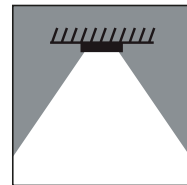

3. flood  
60° up to 90°

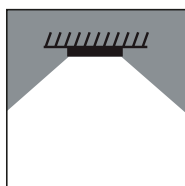

4. wideflood  
90° up to 120°

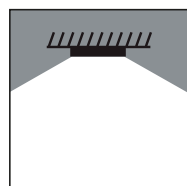

5. superflood  
more than 120°

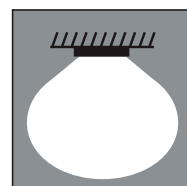

5. frosted



## A variety of options

**It is possible to personalise the product by choosing between different variations of diffusers and optical systems. Optics systems based on lenses - guarantee many different light distributions.**

Outer material	Properties		LUXIONA's diffusers	Construction	Characteristics
Protective glass	Standard	Transparent	1. Optics SH	Tempered glass with lenses	Impact proof and chemical resistant. Varied light distributions.
		Transparent	2. Raster SH	Tempered glass with anti-glare louver	Impact proof and chemical resistant. For low glare applications.
		Matt	3. SHM	Tempered matt glass	Impact proof and chemical resistant. Diffused light
	Antireflective properties	Matt	4. SHMR	Tempered anti-reflective matt glass	Impact proof and chemical resistant. Antireflective for laser use areas. Diffused light
	With PMMA optical diffuser	Micro-prismatic	5. Micro-PRM SH	Micro-prismatic diffuser with tempered glass	Impact proof and chemical resistant for low glare applications
	With PMMA optical diffuser, antireflective properties	Micro-prismatic	6. Micro-PRM SHR	Micro-prismatic diffuser with tempered anti-reflective glass	Impact proof and chemical resistant for low glare applications. Antireflective for laser use areas.
Safety glass	Standard	Matt	7. SLM	Laminated matt glass	Shatterproof and chemical resistant. Diffused light
	Antireflective properties	Matt	8. SLMR	Laminated anti-reflective matt glass	Shatterproof and chemical resistant. Antireflective for laser use areas. Diffused light
	With PMMA optical diffuser	Micro-prismatic	9. Micro-PRM SL	Micro-prismatic diffuser with laminated glass	Shatterproof and chemical resistant for low glare applications
	With PMMA optical diffuser	Micro-prismatic	10. Micro-PRM SLR	Micro-prismatic diffuser with laminated anti-reflective glass	Shatterproof and chemical resistant for low glare applications. Antireflective for laser use areas.
PMMA diffuser	Standard	Opal	11. PLX	PMMA opal diffuser	Plastic diffuser for general applications
	Optical diffuser	Micro-prismatic	12. Micro-PRM	Micro-prismatic diffuser	Plastic diffuser for low glare applications
		Micro-prismatic	13. Micro-PRM PLX-T	Micro-prismatic and PMMA transparent diffuser	Plastic diffuser for low glare applications
PC diffuser	Standard	Opal	14. PC	PC opal diffuser	Impact proof plastic transparent diffuser for general applications

Other diffuser combinations (PLX/PC/PC-T/PRM/Micro-Line) + protecting glass (SH/SL/SHR/SLR) under request. Consult us.



1. Optics SH

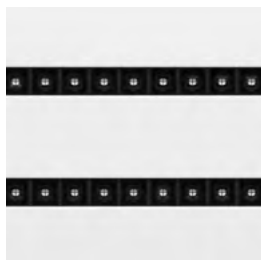

2. Raster SH



3. SHM

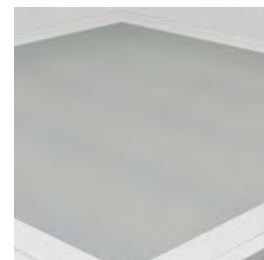

4. SHMR

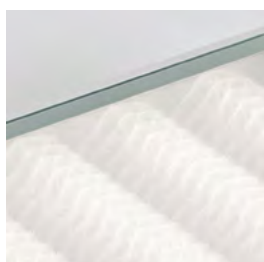

5. Micro-PRM SH, UGR<19

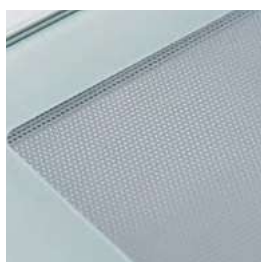

6. Micro-PRM SHR, UGR<19



7. SLM

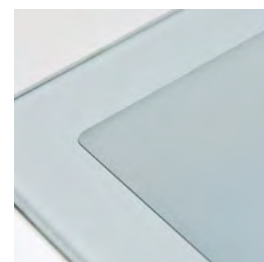

8. SLMR



9. Micro-PRM SL, UGR<19



10. Micro-PRM SLR, UGR<19



11. PLX



12. Micro-PRM, UGR<19



13. Micro-PRM PLX-T,  
UGR<19

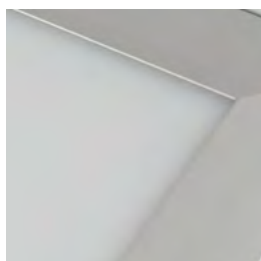

14. PC (polycarbonate)



## Customised gear

Smart lighting opens up a new range of possibilities. It enhances comfort and introduces flexibility enabling significant energy savings. By tuning the tone and brightness of light at a different times of day it's easier to keep everyone focused and alert, especially during long hours while carrying out complicated surgeries or during work in precision engineering and microelectronics industry requiring a high level of focus. Other times it allows to dim or turn off the lighting in the parts of building with less traffic. The luminaires can be also equipped with an emergency module that provides the luminaire with the possibility of emergency operation.

### Casambi

Casambi is a smart lighting system, that allows a mobile device to communicate directly with a luminaire and luminaires to communicate with each other. It uses a low-power radio communication technology that's built into every modern smartphone, laptop, and tablet. Which makes them ideal tools for controlling lighting, colour, or setting up scenes. It helps bring flexibility and personalisation to designs. By using sensors built into fittings it's also possible to respond to different circumstances and share the data in the cloud.

### DALI

DALI is a protocol that enables efficient communication. It works between individual luminaires or groups of luminaires and a control system. It integrates and communicates with other system components such as motion detectors and light sensors, allowing for quick and easy reconfiguration. By use of intelligent LED lighting control, it's possible to save costs associated with lighting, by reducing light intensity in certain working areas which are not currently used or have sufficient daylight.

CASAMBI



 Bluetooth™



CLO ready



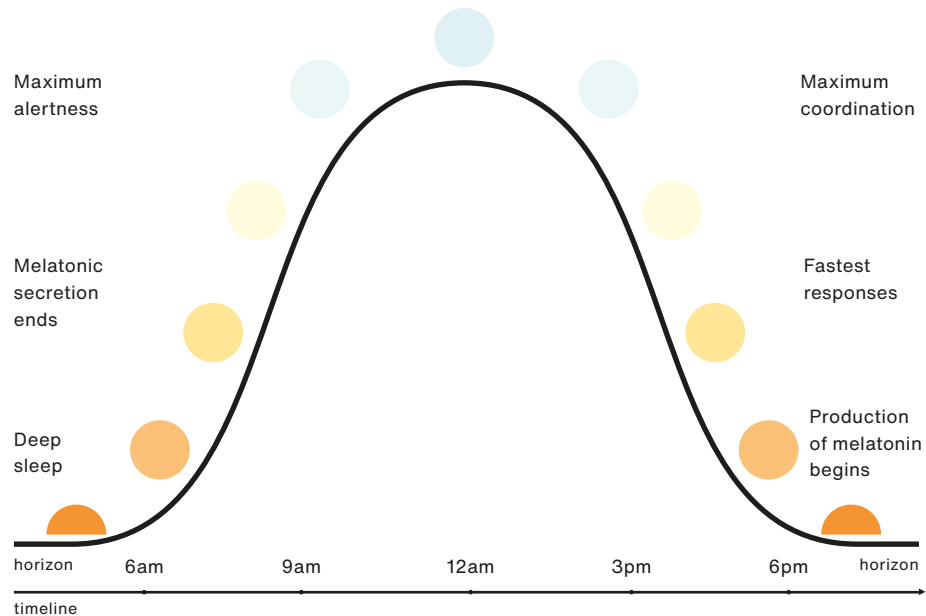

## Patient Centric Lighting

### A perfect light for increased focus, wellbeing and recovery.

Lighting supports physical and emotional well-being with groundbreaking concepts for Human Centric Lighting (HCL), which focuses on people and the optimal light for their needs. For example, it brings the natural course of daylight and its biological effects on patients, medical staff, industry workers, and every other person staying or working in indoor areas with artificial light. This is achieved by using artificial light with the right brightness and colour temperature to supplement the daylight. The interplay of light and room climate creates an atmosphere that has a positive impact on the well-being and recovery of patients, especially the long-term hospital patients. The HCL approach focuses on supporting the body's circadian rhythm, a process that lasts approximately 24 hours. An effective lighting solution taking into consideration the HCL approach uses the colour and the brightness of the light to imitate the changes natural light undergoes throughout the day. It allows us to define levels of visual

comfort and create the correct relationship between lighting levels and colour temperature better suited to our activities, with the help of technologies such as Tunable White.

The greatest benefits of the HCL system are seen in the healthcare sector. Patients are exposed to artificial light for long periods of time. It is important to ensure a natural daytime rhythm, not only to improve wellbeing, but also for faster recovery.

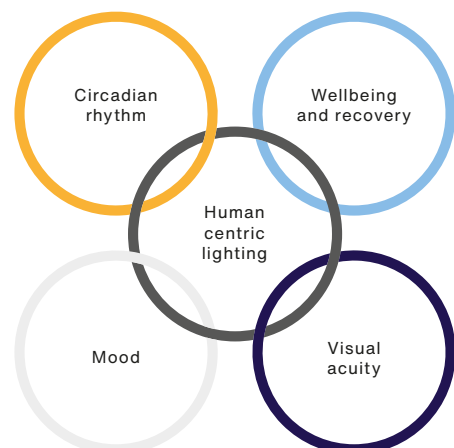

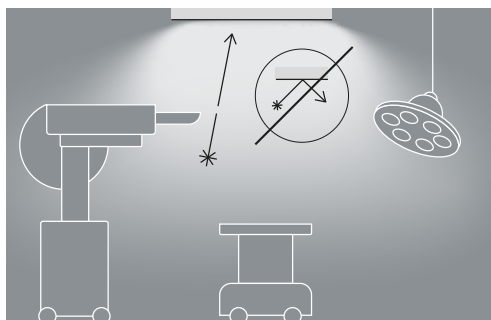

Protection from laser beam reflection

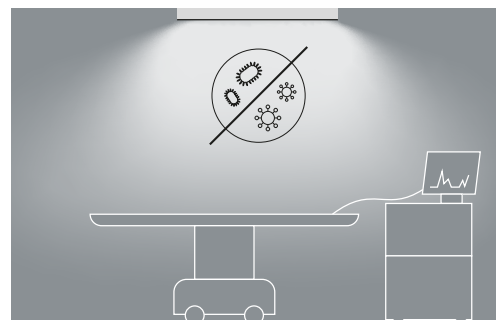

Antibacterial coating preventing from micro-organisms



## Special coatings

### Anti-reflective coating

Special, anti-reflective coating minimizes the reflection of the laser beam. This kind of finishing is used particularly for operating theaters where procedures are performed using laser light beams. To receive this glass property, it is subjected to a special chemical process, that modifies its morphology and chemical composition. It results in a changed layer of glass in the nanometer range giving it unique properties that increase light transmission and reduce reflection losses. Thanks to interfering with the glass structure, the obtained parameters are durable compared to standard coatings, which are deposited on the glass surface. The glass is practically invisible and has a greater (by about 5-10%) light transmittance when using the same LED modules and power supplies. All our Clean ISO luminaires (medical devices) have an anti-reflective coating, in two versions: matt laminated glass with anti-reflective coating - SLMR, or matt tempered glass with anti-reflective coating - SHMR. Clean Standard and Clean Class luminaires can also be fitted with an anti-reflective coated diffuser in customised versions.

### Antibacterial coating

In luminaires dedicated to rooms where clean conditions are essential (particularly in demanding healthcare spaces: operating rooms, intensive care units, or sterile rooms in various industries), it is beneficial to make luminaires with antibacterial coatings. Those special paints contain silver ions that protect against the growth of bacteria and mold on surfaces. Silver as a natural antibiotic destroys about 650 types of pathogenic bacteria. Ions stick to bacterial cell membranes, preventing the secretion of enzymes and neutralizing them. That's why silver is widely used in the production of medical equipment and other equipment intended for use in buildings where a high degree of cleanliness is significant. Installation of luminaires with an antibacterial coating inhibiting the growth of bacteria effectively contributes to the improvement of clean conditions. All our Clean ISO and Clean Class luminaires are equipped with an antimicrobial coating. UV-C luminaires can be fitted with an antimicrobial coating on request.



Mazovian Centre for Treatment of Lung Diseases and Tuberculosis – children's ward, Otwock. Poland



## Imprints for Children Wards

**With a variety of colours available in our offer designers gain real freedom in bringing to life colourful projects intended for medical rooms designed for children.**

The possibility of painting some of our luminaires according to the RAL palette is another step toward limitless creativity. While the white luminaire can be easily integrated with the ceiling or walls, sometimes it's necessary to create a visual diversity between them. The vivid colour of a luminaire can become an eye-catching highlight or brighten up a children's ward and help young patients feel more comfortable in such as stressful environment as a hospital.

### Customisable dimensions

The products from our offer can be personalised in terms of length, width or diameter, giving you limitless possibilities and allowing you to match the product perfectly to the space.





Veneto Vidas Hospitals, Milan. Italy



Veneto Vidas Hospitals, Milan. Italy 27

# From extreme to standard clean requirements

**After years of ongoing development, our experts made perfect use of the experience drawn from clean-room projects and combined it with the very latest lighting technology. It results in a complex solution with a three-level luminaire concept for clean rooms: Clean ISO luminaires, Clean Class luminaires, and Standard Clean luminaires. It is based on PN-EN ISO 14644 -1: 2005 norm for Clean rooms and other controlled environments with defined pollution levels related to the particles size. A wide selection of products divided into three separate categories answers to all the needs of different clean environments as well as particular visual tasks in each and every clean sector.**

The Standard specifies lighting requirements for indoor workplaces where the needs of visual comfort and visual performance of normally sighted people meet. The document contains requirements for all typical visual tasks, including workplaces equipped with screen monitors. The requirements specify both quantitative values and qualitative characteristics of lighting. The Standard additionally provides recommendations for good lighting practice.

EN 12464-1 does not recommend specific solutions or limit the freedom of designers to use new techniques or innovative lighting devices. Lighting can be produced by daylight, artificial light or a combination of both.

In order to reach such levels of illuminance at bed level, high lumen outputs shall be used. LUXIONA provides up to 11000 lumens for a 60x60 fittings and 18000 lumens for 120x30cm fittings.

## Lighting requirements in EN 12464-1

Type of task/ activity area	$E_m$ lx		$U_0$	$R_a$	$R_{UGL}$	$E_{m,z}$ lx	$E_{m,wall}$ lx	$E_{m,ceiling}$ lx	Specific requirements
	Required	Modified							
General lighting	500	750	0,60	90	19	150	150	100	$4000 K \leq T_{cp} \leq 5000K$
Examination and treatment	1000	1500	0,70	90	19	150	150	100	$4000 K \leq T_{cp} \leq 5000K$



ISO  
13485

## Clean ISO luminaires (Medical device)

### Light for health

For the health sector, the luminaires must have not only the highest cleanliness level but also provide excellent lighting conditions to help perform the most difficult tasks, especially when the concentration of doctors and medical staff is a key to successful medical procedures. For the operating theatres, luminaires with the highest luminous intensities are recommended. The blue light spectrum helps stay focused and alert and helps to kill bacteria. Luminaires with a stronger green light spectrum are perfect to calm down patients and reduce the feeling of pain.

Clean ISO luminaires are recommended for:  
 Operating theaters. Intensive care rooms / ICU. Rooms that are intended for laparoscopic and endoscopic procedures.  
 Recovery rooms after surgery Dermatology offices.  
 Blood collection points.



Agat Clean ISO LED  
CRI95



Agat Clean ISO  
No Frame LED  
CRI95



Rubin Clean ISO  
LED CRI95



Rubin Clean ISO No  
Frame LED CRI95

Product submitted and registered in the Office for Registration of Medicinal Products, Medical Devices and Biocidal Products.

Compatible with basic requirements defined in directives of European Union: Directive of the Council 93/42/EEC (MDD) and the Directive of European Parliament and the Council 2007/47/EC.

Fulfils the requirements defined in the bill of February 3rd 2017 about Medical Products.

Tested and compatible with European norm PN-EN 60601-1, PN-EN 60601-1-2 (Medical electric devices-overall safety requirements and basic technical requirements).



ISO  
14644

## Clean Class luminaires

### Light for industry

Design for clean luminaires intended for the industry provides light for demanding visual tasks in pharmaceutical and chemical production facilities, laboratories, the food industry, and other industrial cleanrooms. Our luminaires have been developed under strict cleanliness principles, meet all legal requirements for selected cleanliness classes, and are highly efficient. The result is effective lighting, with the simplified body design resistant to dust particles, moisture, and to disinfectants used in many clean rooms.

### Airborne Particulate Cleanliness Classes

Depending on the requirements, the cleanliness of the clean rooms is divided into classes in which the amount and size of the pollution per cubic metre of the atmosphere are defined. The table shows the number of particles per m<sup>3</sup> of air permissible in a room of a given ISO cleanliness class. It also includes the particle size expressed in micrometres in accordance with EN ISO 14644. For example, in an ISO Class 3 room, 35 particles per m<sup>3</sup> of 0.5 microns are allowed.

Class	Number of Particles per Cubic Metre by Micrometre Size					
	0.1 micron	0.2 micron	0.3 micron	0.5 micron	1 micron	5 microns
R9						
ISO 3	1000	237	102	35		
ISO 4	10000	2370	1020	352	83	
ISO 5	10000	23700	10200	3520	832	29
ISO 6	100000	237000	102000	35200	8320	293
ISO 7				352000	83200	2930
ISO 8				3520000	832000	29300
ISO 9				35200000	8320000	293000

#### Class 3-4

Pharmaceutical production: rooms used for tablets production, weighing, filling, making aseptic connections and film coatings; Electronic Industry: Displays production, semiconductors production (electrotechnics).

#### Class 5-6

Sterilizations, plaster rooms within operating theatres, „Clean” corridors of operating theatres; Chemical industry: production of household chemicals and cosmetics; Research laboratories (with laminar chambers) e.g. microbiological; precision production (microelectronics and microoptics), medical equipment production, computer components production.

#### Class 7-8-9

Chemical industry, plastics - oil industry, glass industry, precision castings; Food industry-Preparation rooms, food production and initial packaging processes; Solutions and film coatings preparation rooms; After wash components procedure, later filling and film coating; Clean room production surroundings / clean production.

**Class 3-4**



Agat Clean Class  
3-4 LED



Agat Clean Class  
3-4 No Frame LED



Rubin Clean Class  
3-4 LED



Rubin Clean Class  
3-4 No Frame LED

**Class 5-6**



Agat Clean Class  
5-6 LED



Agat Clean Class  
5-6 No Frame LED



Rubin Clean Class  
5-6 LED



Rubin Clean Class  
5-6 No Frame LED

**Class 7-8-9**



Agat Clean Class  
7-8-9 LED



Rubin Clean Class  
7-8-9 LED



IP  
65

## Standard Clean luminaires

### Light for improved care

The Standard version of the CLEAN luminaire focuses on basic clean-room requirements such as improved cleanliness level compared to traditional luminaires and ease of cleaning. The high-level tightness and protection from dust particles are combined with luminaires' effectiveness and ability to provide pleasant, uniform lighting.

Doctors and nurses stations/offices, maternity wards, ophthalmology and laryngology offices, delivery rooms, treatment rooms, dental offices, laboratories, decontamination rooms, inspection rooms.



Emergency Medical Service, Pruszcz Gdanski. Poland



The Dialysis Station and the Nephrology Department of the Provincial Hospital, Lomza. Poland



BHU Linemed Triangle LED



Agat Clean Eco LED



Agat Clean LED



Agat Clean LED Smooth



Agat Clean No Frame LED



Agat Clean Pos LED



Agat Clean Slight LED

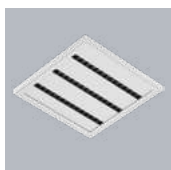

Domino Clean Surface Low UGR LED



Domino Clean Low UGR LED



Topaz ODG Clean AL LED



Topaz ODG Clean ST LED Smooth



Rubin Clean LED



Rubin Clean LED Smooth

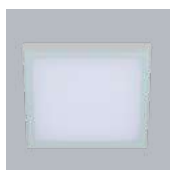

Rubin Clean No Frame LED



Rubin Clean-Eco LED

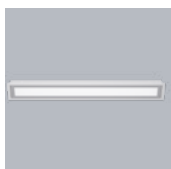

Rubin Clean Corner



Agat Clean Eco LED CRI95



Agat Clean LED CRI95



Agat Clean No Frame LED CRI95



Rubin Clean LED CRI95



Rubin Clean No Frame LED CRI95



Agat Clean LED Tunable White

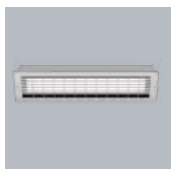

Rubin Clean Corner Inox LED



Agat Clinic

CRI >80	60000h L80/B10	SDCM 3	3000 K	4000 K
------------	-------------------	-----------	-----------	-----------

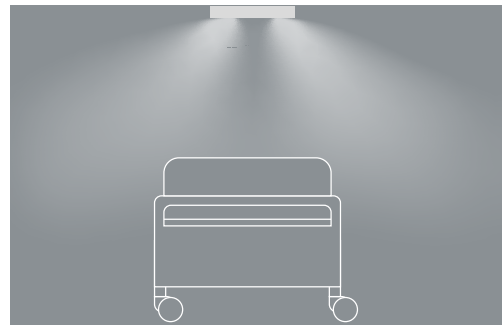

1. Soft light ambiance - 140°

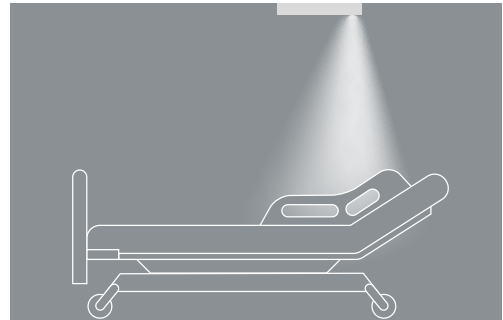

2. Reading light - 20°

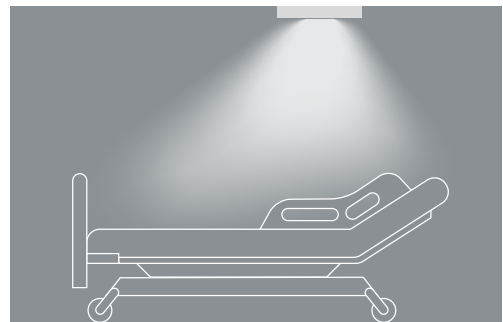

3. Recognition light - 90°

## Agat Clinic for patient room

**The luminaire especially created for use in health & care facilities. This innovative lighting ensures the comfort and safety of patients, providing them with as many as three different light distributions that answer to all their needs.**

This modern luminaire is designed for modular suspended ceilings. With highly efficient LED panels Agat Clinic ensures top, energy-saving performance. The housing of the luminaire is made of steel sheet, powder coated in white. Equipped with three separate electrical circuits is adapted to the emission of as many as three different light distributions. The first mode is perfect for examining a patient. The main, direct light distribution is achieved with the use of two opal PMMA diffusers: micro prismatic and smooth with a luminous

flux of approx. 3300 lm.

The second, indirect light distribution, provides soft, relaxing, and very pleasant light. It is perfect for moments during the day when a patient is resting. In this mode, the luminaire provides 900 lm of luminous flux. The last distribution, with a strongly focused beam of light, makes sure to provide necessary light without disturbing other patients in the room, perfect for reading. Provided with an anti-glare raster and a luminous flux of about 700 lm.



BHU Linemed Triangle

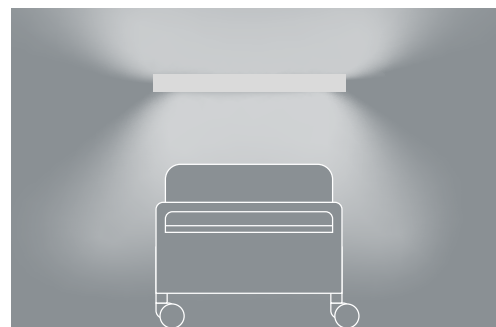

## Bed Head Unit

**An efficient solution for patients room providing different kinds of comfortable lighting combined with power supply and emergency equipment.**

BHU Linemed bedside panel, designed for installation in hospital rooms. A solution combining the functions of lighting, power supply, call system and ICT connections. The panel provides: general lighting of the room with reflected light, local lighting for examination and reading, night lighting, 230 V electric sockets, data

sockets, equipotential socket, light switch. Panel entirely made of aluminium profiles, powder-coated. Panel covered with antibacterial coating. The luminaire is made of PLX - opal PMMA. The luminaire is fitted with two 230 V electrical sockets and three key light switches.

# UVC disinfection lighting

No bacteria, viruses, and fungi on the surface thanks to UV-disinfection luminaires. Those are one of the most effective devices capable of destroying the DNA or RNA of any exposed microorganisms. The technology using ultraviolet light is an effective, convenient, and cost-efficient method of disinfection, that does not require human labor. It is also environmentally friendly by minimising the use of chemical disinfectants.

## Why does UV-C disinfect?

The UV-C radiation of a low pressure lamp consists of a single spectral line of radiation at 254 nm, which is located in the area of maximum germicidal effect of the UV-C: between the wavelengths of 250 and 270nm.

Thanks to the absorption of energy from UV-C radiation by ribonucleic acids and proteins the molecular structure of the microorganisms, meaning its DNA and RNA falls apart.

### UV-C Germicidal effectiveness

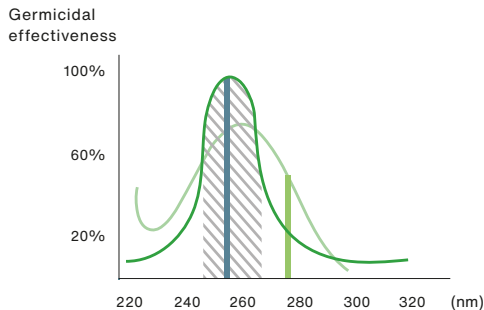

- Optimal germicidal effect curve
- DNA absorption curve
- ▨ Area of greatest germicidal effect of UV-C radiation in the 250-270nm wavelength range
- UV-C Low Pressure Radiation at 254nm
- UV-C LED radiation in a 280nm wavelength with very low germicidal effect

### Molecular structure (DNA+RNA)

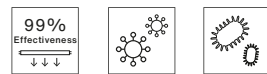
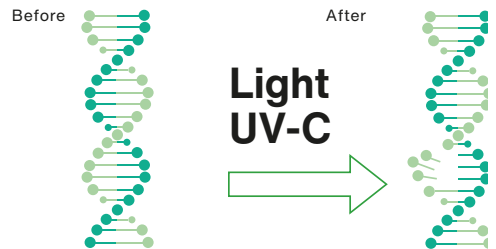

99.9% effectiveness against microorganisms

## Why did we choose low-pressure radiation as the source?

Sources of low pressure UV-C radiation are more effective than LEDs in their germicidal effect and are currently the only source of light for applications in large spaces.

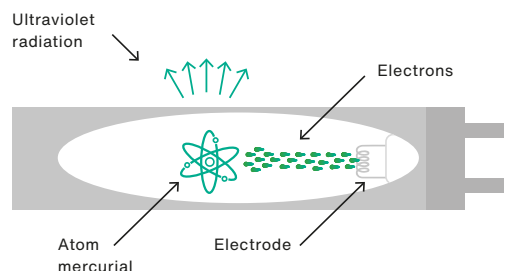

## Disinfection by direct radiation

### Air and surface disinfection by direct exposure to UV-C radiation.

The benefit of direct UV-C radiation is short time of disinfection and no need for room ventilation. It also eliminates unpleasant smells. While surfaces hidden from direct emission won't be disinfected, some materials

not resistant to UV-C radiation (eg. some types of polymers) may be affected by direct exposure to it. The luminaires are not safe to be present during the radiation.

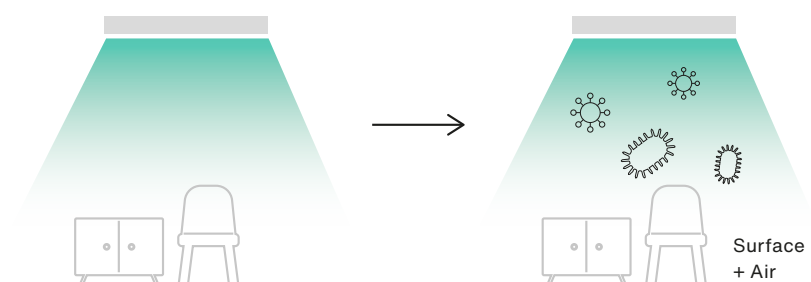

Living beings CANNOT be present during radiation.

## UVC-FLOW air disinfection

### Disinfection of the air through UV-C radiation, by air circulation inside the disinfection chamber.

Perfect for enclosed spaces. It takes longer than direct disinfection but as opposed it, it is safe to be present during the disinfection process. Technology removes bad odors and

is equipped with a low noise emission fan. Maintenance of this solution is easy thanks to its construction that keeps electrical components protected from dust and radiation.

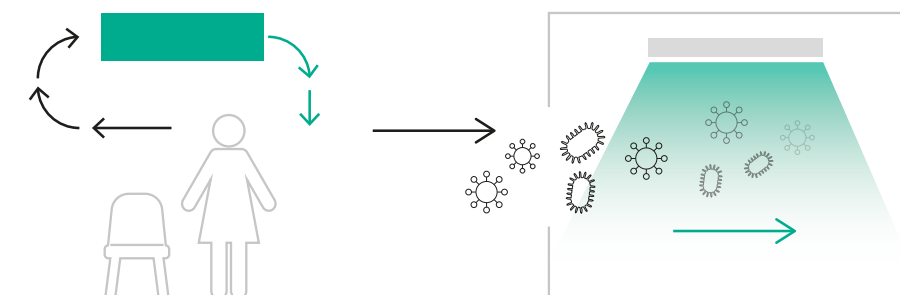

Disinfection by air circulation inside the disinfection chamber, safe for living beings.

## LUXIONA's disinfection luminaires

**Everywhere that it's needed our UV-C radiation luminaires are effective disinfectants for air and surfaces, that help mitigate the risk of infections. With a wide selection of professional solutions, it's easy to find the perfect application to a chosen space.**

Years of experience in lighting has led us to develop a wide range of UV-C disinfection luminaires, ideal for air and surfaces disinfection. This includes products both in direct disinfection technology and air flow technology, perfect for a wide range of applications in hospitals, medical facilities, schools, offices, factories or a public spaces used daily by a

large number of people. Made from high-quality, durable, UV-C resistant materials, our lighting solutions are created to provide dependable disinfection over the long lifetime. This is supported by our experience and highest standards manufacturing processes to guarantee the best quality.

Disinfection		Risk class	Body	Assembly	Optional			
Airstream UV-C	UV-C flow air	RG0	Steel sheet painted in white	Direct to the ceiling or on the wall (version W)	Motion sensor (turns off the luminaire in the case of detecting human presence)	Optional protective foil for T8 sources (glass protection in the case of fluorescent lamp cracks) version with bactericidal coating.	Mounting on a dedicated stand with wheels (possible montage in vertical and horizontal position)	Timer (optional). Monitoring the hours of lamp source operation.
				On the portable stand with wheels (version GM)				
Agaline UV-C	Direct UV-C	RG3		Direct to the ceiling or on the wall (version W)		Version with bactericidal coating	Modes of operation: delayed shutdown, delayed switching on, cyclic shutdown, cyclical switching, delayed momentary switching on	
				On the portable stand with wheels (version GM)				
Oktan UV-C				On the wall (version Oktan W)				
				On portable stand with wheels (version Oktan GM)				
Universal UV-C			Direct to the ceiling or in modular suspended ceiling or in plasterboard ceilings using a dedicated frame					



### Airstream UV-C

Luminaire's sealed chamber uses air flow and allows the whole disinfection process to take place inside the housing, which makes it completely safe for everyone present in the disinfected rooms. The high-quality design protects from dust and is also covered with an antibacterial coating. All the components used in luminaire are UV-resistant and easy to maintain. Light sources contain a small amount of mercury - for the first 100 hours of operation, light sources emit a small amount of ozone. After using it, it is recommended to ventilate the room.

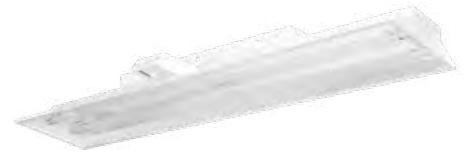

### Agaline UV-C

LUXIONA's bactericidal luminaire that effectively and irretrievably eliminates all viruses, bacteria and fungi. It's especially dedicated to disinfect rooms in hospitals, food factories, offices or a public spaces used daily by a large number of people. Luminaire has photobiological risk class (IEC/EN 62471) - RG3 (high risk), and can threat even during a short exposure. Light sources contain a small amount of mercury - for the first 100 hours of lamp operation, light sources emit a small amount of ozone. After using it, it is recommended to ventilate the room.



### Oktan UV-C

Luminaire is perfect for use wherever mounting permanent luminaires is not possible. Its compact and portable standing case allows to place it anywhere: on table, shelves or floor. It can be also equipped with a portable stand. Luminaire with high photobiological risk class (IEC/EN 62471) - RG3, dangerous even during a short exposure. Light sources contain a small amount of mercury - for the first 100 hours of lamp operation, light sources emit a small amount of ozone. After using it, it is recommended to ventilate the room.



### Universal UV-C

This bactericidal luminaire with simple design and easy installation is especially dedicated for compact fluorescent lamps TC-L, intended for disinfecting medical spaces and laboratories. The universal modular device allows for direct installation on the ceiling or in suspended modular ceilings. It's high photobiological risk class (IEC/EN 62471) - RG3 endangers our health even during a short exposure. It is not allowed to use them together with general lighting.



## ALVO® Ultra V-bot

### Innovative and automated UV-C solution

**ALVO® Ultra V-bot is a device for bio-decontamination using UV-C light, with proven technology to reduce biological contamination. The technology used in the ALVO® Ultra V-bot monitors and adjusts the disinfection process to ensure the most optimal results in reducing surface and air pollution.**

ALVO Ultra® V-bot is equipped with sensors and scanners which create a virtual map of the scanned area. After the room has been mapped, the operator indicates in the user application, the zones (points) the robot should reach in order to perform decontamination. The disinfection process is activated by the operator remotely, from a tablet, after he has safely left the room (Wi-Fi communication). Thanks to the safety system and autonomous navigation, the ALVO® Ultra V-bot avoids with any equipment it would meet on the way and moves safely around the scanned environment. Compared to manual robots, ALVO® Ultra V-bot performs a repeatable, precise procedure that has been programmed.

The quality of the process is maintained at the same level and monitored each time. The direct medical cost related to Healthcare-Associated Infections (HAIs) in US hospitals exceeds \$10 billion annually. ALVO® Ultra V-bot significantly lowers the risk of dangerous, preventable infections transmitted by contaminated surfaces. This way saving hospitals from vital costs. Eradicating dangerous pathogens from the environment will be required not only in hospitals in the 'new normal'. ALVO® Ultra V-bot delivers excellent outcomes in all vital public spaces: concert halls, schools, production plants, sports centres, shopping malls, laboratories etc.



# Hospital lighting solutions for every space

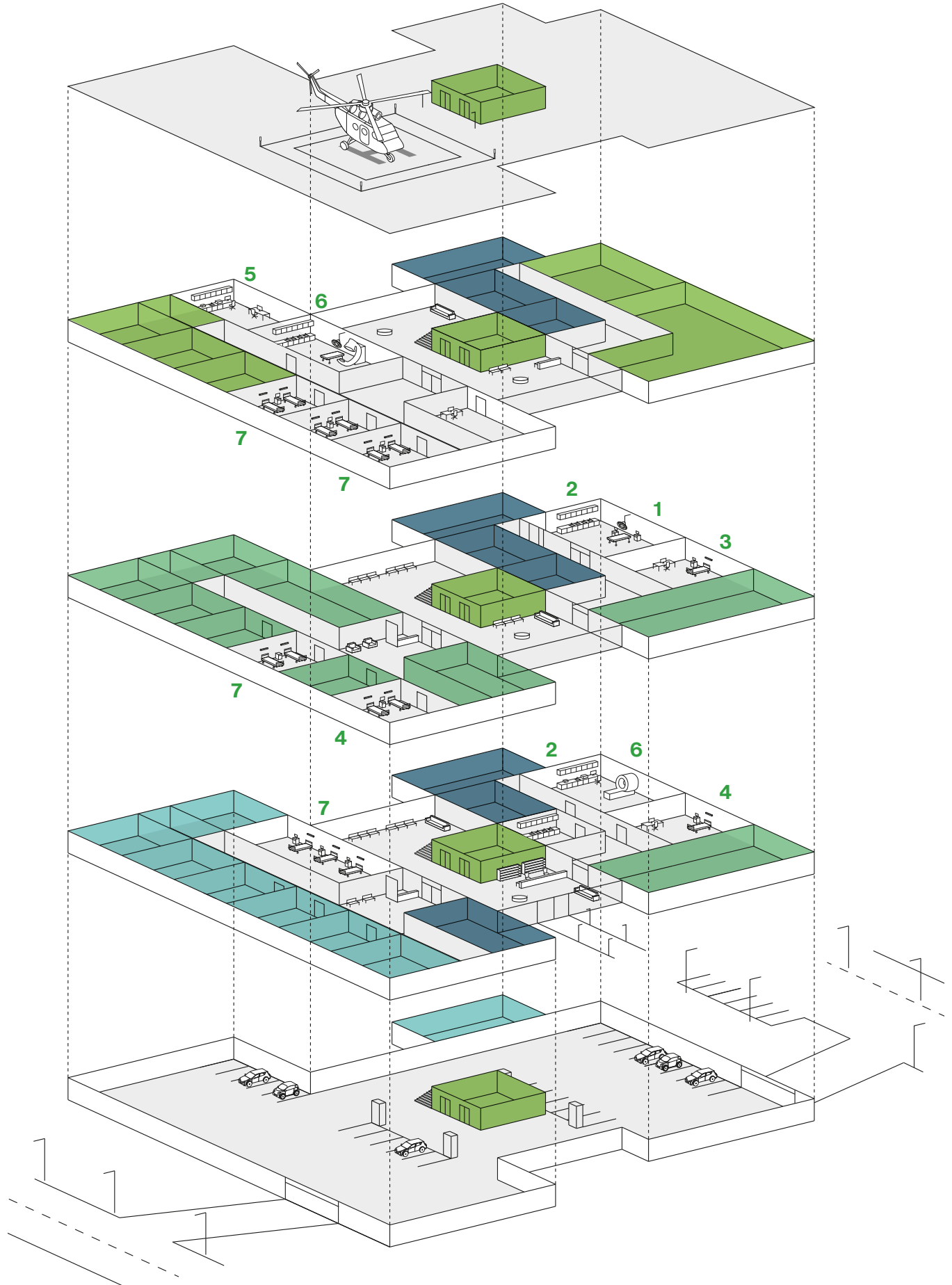

**1 Operating theatres - surgery rooms**



**2 Surroundings of operating theatres (clean corridors)**



**3 Intensive care rooms (ICU)**



**4 Post-surgery recovery rooms**



**5 Blood extraction rooms**



**6 Laparoscopic & Endoscopic procedure rooms**



**7 Patient rooms**

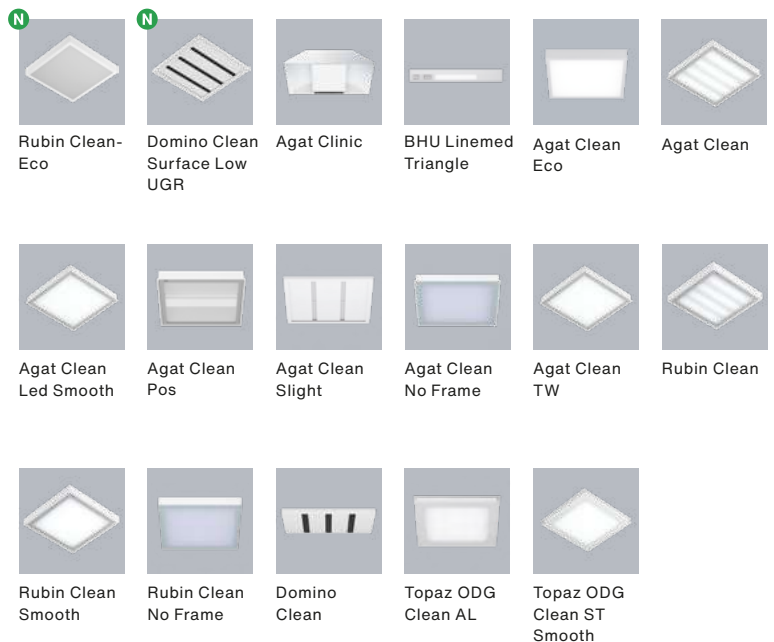

# Hospital lighting solutions for every space - continuation

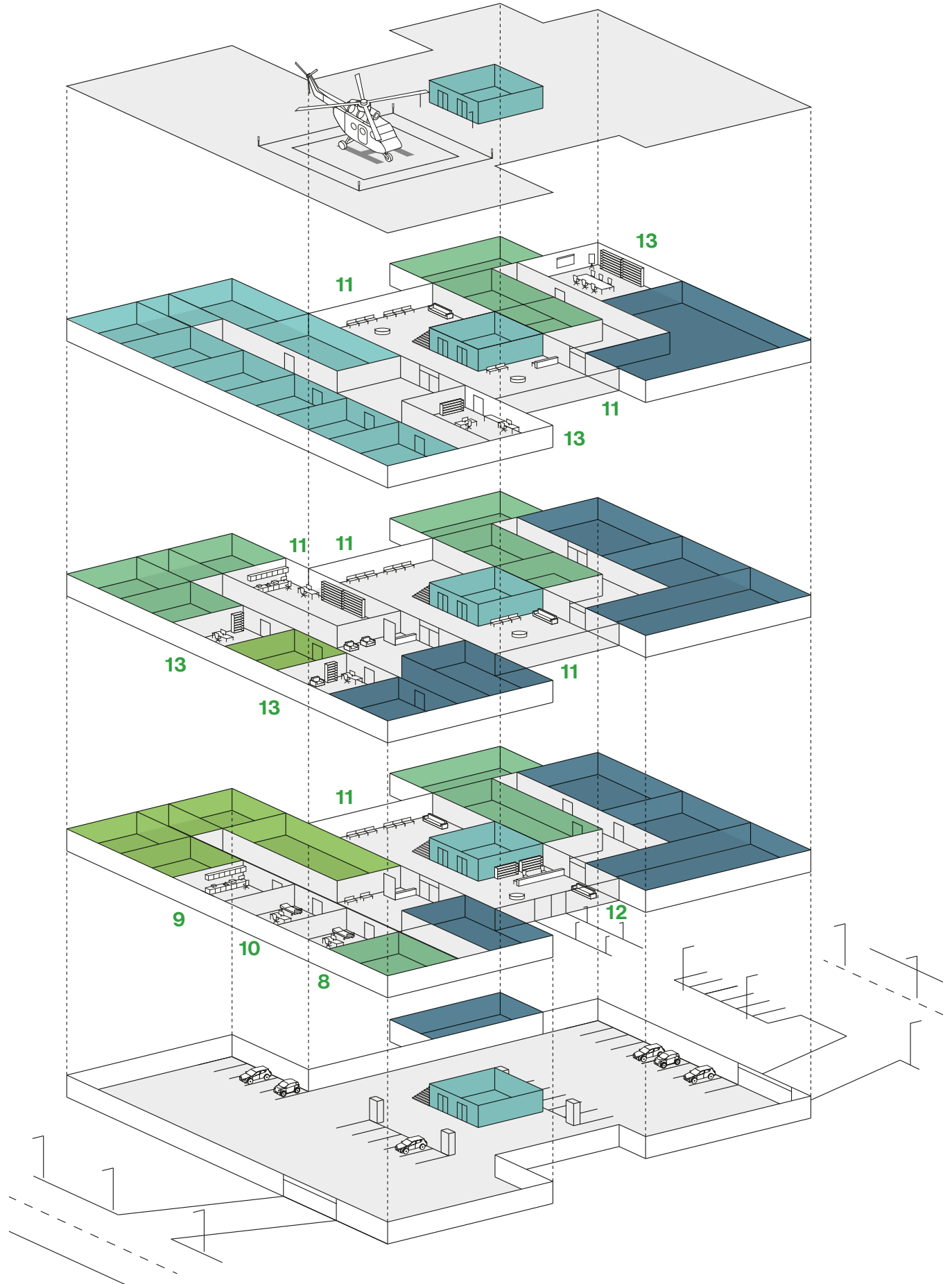

**8 Consultancy & Doctors rooms**











































**9 Laboratories**

**10 Dermatology & Dental offices**

**11 Common areas: corridors, waiting areas**

**12 Receptions**

**13 Doctors common offices**

					
Rubin Clean-Eco	Domino Clean Surface Low UGR	Agat Clean Eco	Agat Clean	Agat Clean Smooth	Agat Clean Pos
					
Agat Clean Slight	Agat Clean No Frame	Agat Clean TW	Rubin Clean	Rubin Clean Smooth	Rubin Clean No Frame
					
Domino Clean	Topaz ODG Clean AL	Topaz ODG Clean ST Smooth			
					
Agat Slim	Snake V	Beryl New K	Beryl New O	Beryl Surface K	Beryl Surface O
					
Patos O	Patos Line	Versatile			
					
X-Line Pro	X-Line Slight	Luxcan Pro*	Artshape Sq	Artshape Three	Snake V
					
Flying Surface	Luxcan C	Luxcan Mini	Luxcan R	Lumbo	
					
X-Line Pro	X-Line Slight	Agat Pos	Agat Deco Smooth		
					
Snake V	Europanel	Domino			

# Clean factory lighting solutions for every space

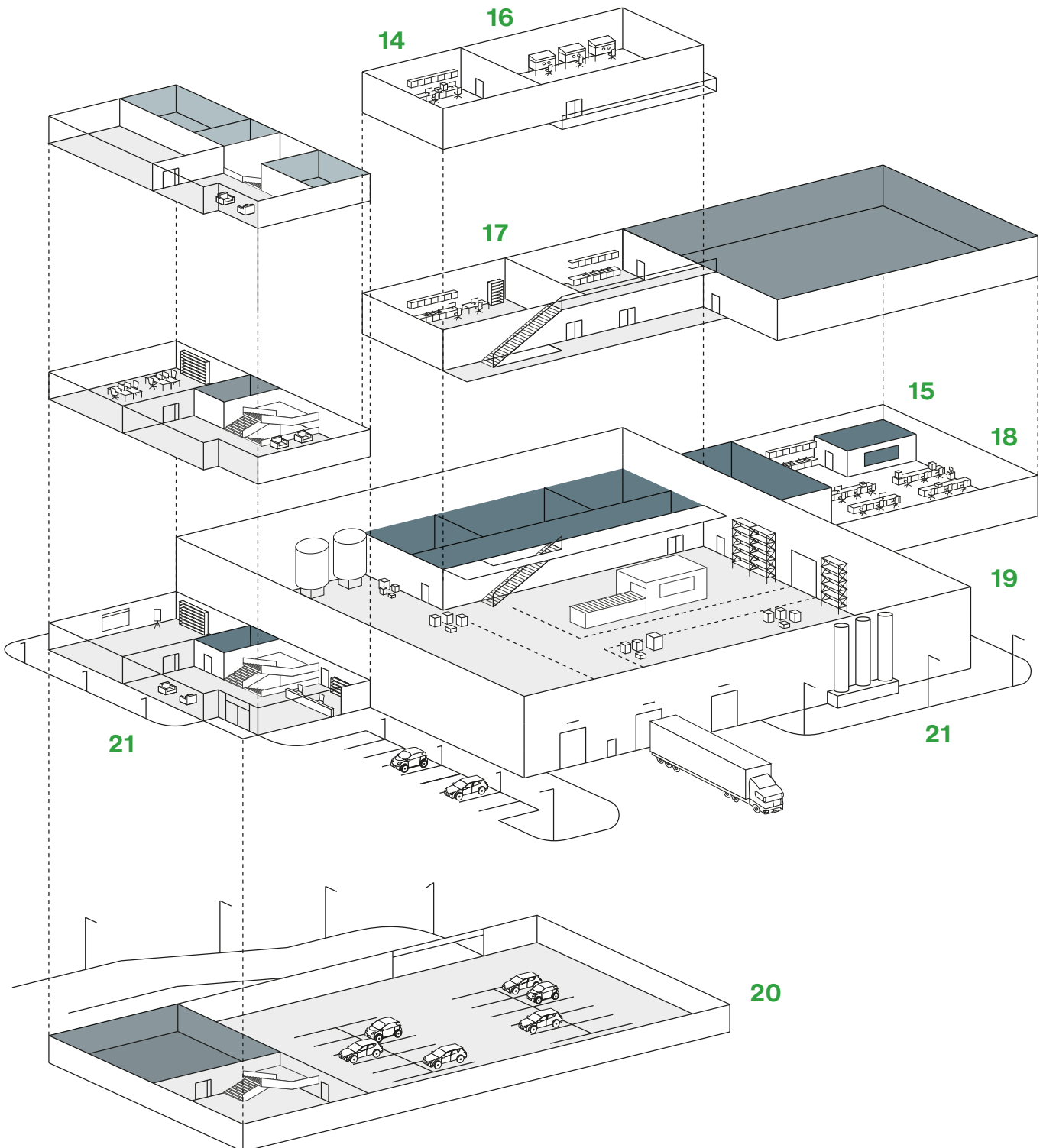

**14 Research laboratory & Pharmaceutical laboratory**



**15 Clean rooms**



**16 Research laboratories with laminar chambers**



**17 Research laboratories without laminar chambers**



**18 Precision production**



**19 Food industry**

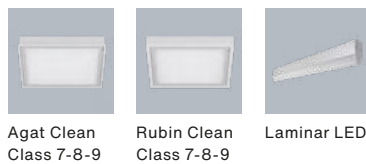

**20 Underground car parks**



**21 Outdoors: gardens, car parks**

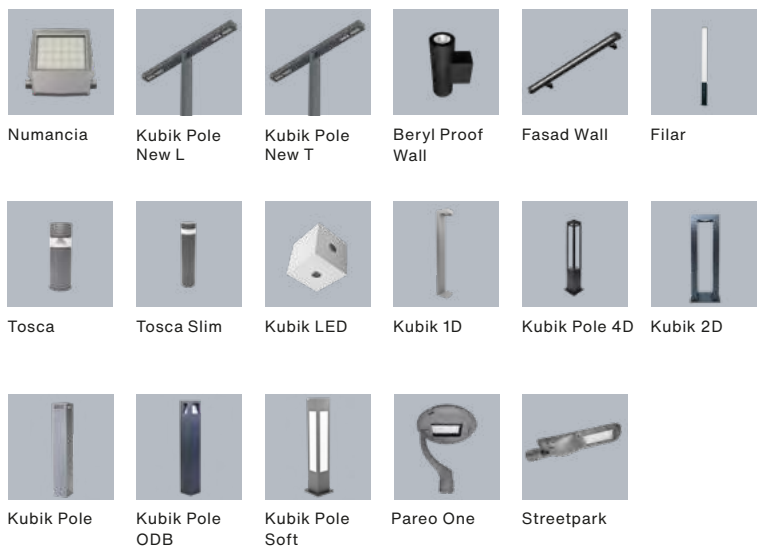



Agat Clean LED Smooth

- Operating theatres - surgery rooms**
- Surroundings of operating theatres (clean corridors)**
- Intensive care rooms (ICU)**
- Post-surgery recovery rooms**
- Blood extraction rooms**
- Laparoscopic & Endoscopic procedure rooms**

Patient rooms

Consultancy & Doctors rooms

Laboratories

Dermatology & Dental offices

Common areas: corridors, waiting areas

Receptions

Doctors common offices

Research laboratory & Pharmaceutical laboratory

Clean rooms

Research laboratories with laminar chambers

Research laboratories without laminar chambers

Precision production

Food industry

Underground car parks

Outdoors: gardens, car parks

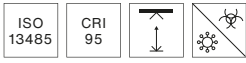

### Agat Clean ISO CRI 95

Efficient luminaire made of steel sheet with optical systems and diffusers mounted in aluminium frame. Perfect for module suspended ceilings.



### Agat Clean ISO No Frame CRI95

Perfect for demanding conditions excluding any contamination. Luminaire without a frame nor visible elements joining diffuser and luminaire's body.



### Rubin Clean ISO CRI 95

Highly efficient surface mounted luminaire made from steel sheet with diffusers and optical systems placed in aluminium frame.



### Rubin Clean ISO No Frame CRI95

Highest protection from contamination combined with efficient LED panels. Luminaire without aluminium frame.

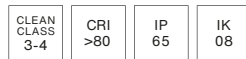

### Agat Clean Class 3-4

Designed to module, gypsum and cardboard suspended ceilings. Combines a comfortable lighting with high performance.

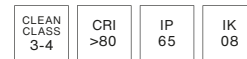
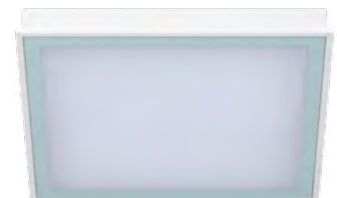

### Agat Clean Class 3-4 No Frame

The luminaire is intended for clean rooms with an increased ISO 3-4 cleanliness class. Designed for suspended modular ceilings, equipped with highly efficient LED panels. Available with a wide range of diffusers.

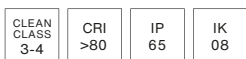

### Rubin Clean Class 3-4

Comfortable lighting and efficiency thanks to modern LED panels. Luminaire with diffusers and optical systems placed in aluminium frame.



### Rubin Clean Class 3-4 No Frame

Perfect solution for clean rooms that excludes any unwanted contamination. Luminaire thanks to lack of aluminium frame.

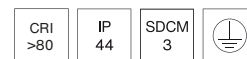

### Laminar LED

Streamlined, oval shape that makes it suitable for rooms with laminar flow ventilation. The air flowing around the luminaire is less susceptible to mechanical resistance. LED modules with color temperature 4000 K or with monochromatic yellow light.





Non-Invasive Medicine Centre, The University Clinical Centre, Gdansk. Poland



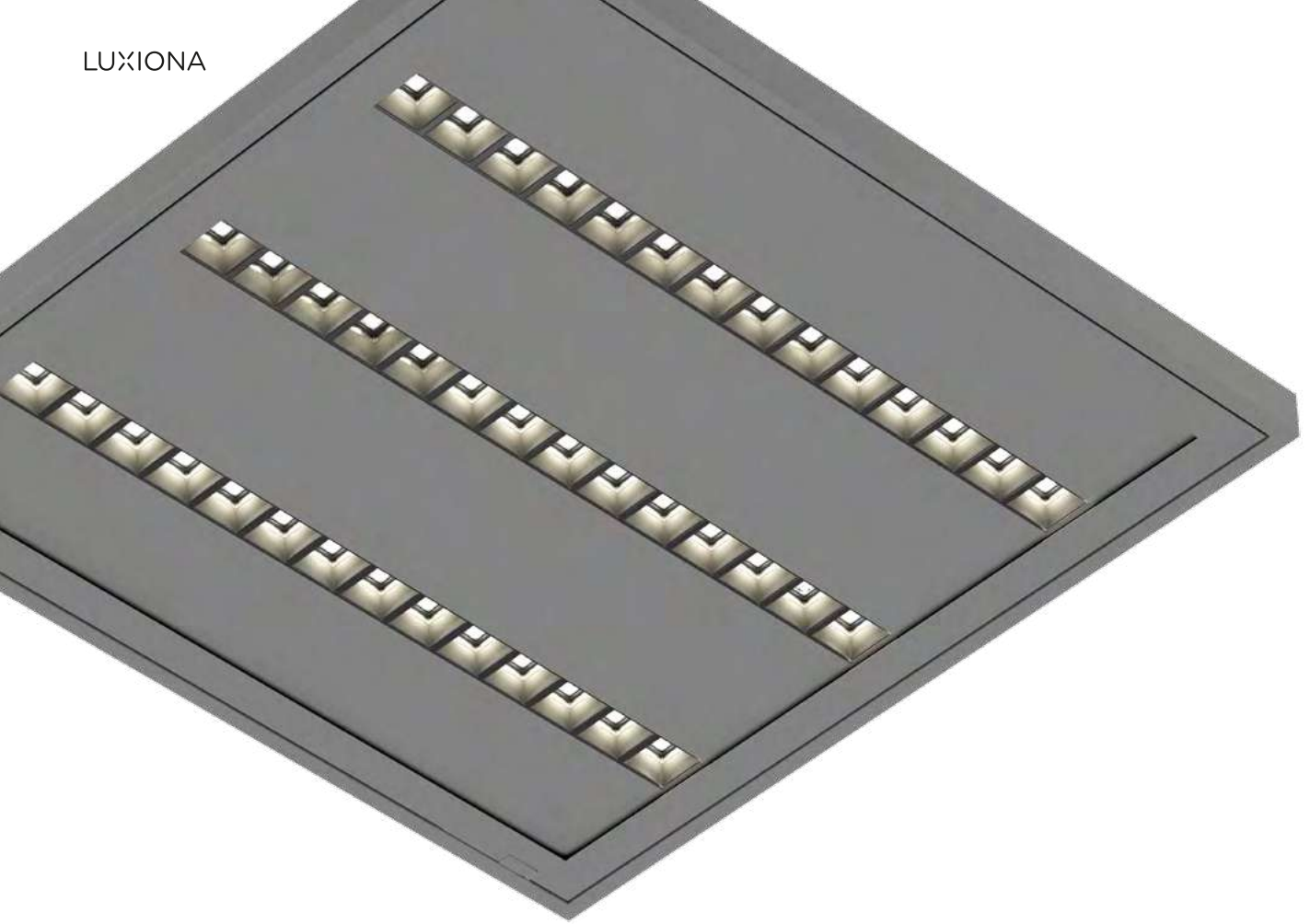

Domino Clean Surface Low UGR LED **N**

- Operating theatres - surgery rooms
- Surroundings of operating theatres (clean corridors)
- Intensive care rooms (ICU)
- Post-surgery recovery rooms
- Blood extraction rooms
- Laparoscopic & Endoscopic procedure rooms

## **Patient rooms**

- Consultancy & Doctors rooms
- Laboratories
- Dermatology & Dental offices
- Common areas: corridors, waiting areas
- Receptions
- Doctors common offices
- Research laboratory & Pharmaceutical laboratory
- Clean rooms
- Research laboratories with laminar chambers
- Research laboratories without laminar chambers
- Precision production
- Food industry
- Underground car parks
- Outdoors: gardens, car parks

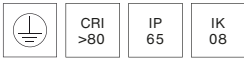

### Rubin Clean-Eco N

Surface-mounted internal luminaire for clean and medical facilities, characterised by high energy efficiency, long service life and versions with CRI>95, ensuring excellent colour rendering.

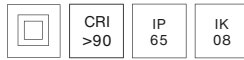
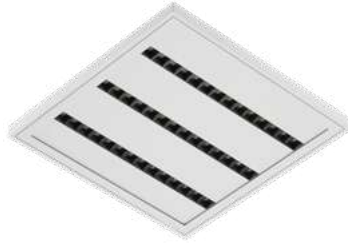

### Domino Clean N Surface Low UGR

High-efficiency surface-mounted luminaire designed for clean and medical environments, featuring advanced anti-glare louvers that ensure exceptional visual comfort and superior quality of light.



### Agat Clinic

New and innovative solution that ensures the comfort of patients, providing them with three different light distributions that answer all their needs.

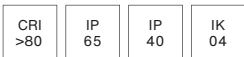
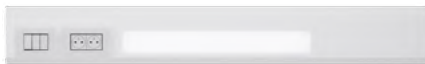

### BHU Linemed Triangle

Modern BHU panel, indispensable in hospital rooms. Combines ambient lighting with a life saving equipment: a power supply, call system and ICT connections.



### Agat Clean-Eco

Luminaire designed to module suspended ceilings. Luminaire body made from steel sheet. Diffusers permanently mounted, no aluminium frame.

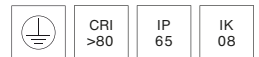

### Agat Clean

Luminaire designed to module and plasterboard suspended ceilings. Luminaire body made from steel sheet. Optical systems and diffusers mounted in an aluminium frame.

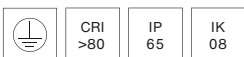

### Agat Clean LED Smooth

Luminaire designed to module and plasterboard suspended ceilings. Luminaire body made from steel sheet. The product ensures a homogeneous distribution of light.



### Agat Clean Pos

LED luminaire designed to module and plasterboard suspended ceilings. Luminary design prevents from dazzle effect.



### Agat Clean Slight

Luminaire designed to module suspended ceilings. Light distribution made by using high performance lenses.



Topaz ODG Clean ST Smooth

Operating theatres - surgery rooms

Surroundings of operating theatres (clean corridors)

Intensive care rooms (ICU)

Post-surgery recovery rooms

Blood extraction rooms

Laparoscopic & Endoscopic procedure rooms

## **Patient rooms - continuation**

Consultancy & Doctors rooms

Laboratories

Dermatology & Dental offices

Common areas: corridors, waiting areas

Receptions

Doctors common offices

Research laboratory & Pharmaceutical laboratory

Clean rooms

Research laboratories with laminar chambers

Research laboratories without laminar chambers

Precision production

Food industry

Underground car parks

Outdoors: gardens, car parks

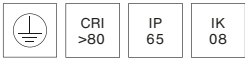

### Agat Clean No Frame

Luminaire designed to module and plasterboard suspended ceilings. Luminaire body made from steel sheet. Lack of aluminium frame.

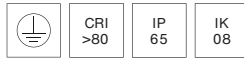

### Agat Clean TW

Luminaire designed to module and plasterboard suspended ceilings. Luminaire body made from steel sheet. Tunable White LED sources.



### Rubin Clean

Surface mounted luminaire. Luminaire body made from steel sheet. Diffusers and optical systems in aluminium frame.

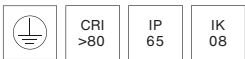

### Rubin Clean Smooth

Surface mounted luminaire. Luminaire body made from steel sheet. The product ensures a homogeneous distribution of light.

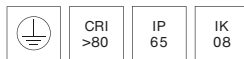

### Rubin Clean No Frame

Luminaire perfect for clean rooms. Without frame or visible elements joining the diffuser with luminaire's body it provides contamination-free conditions.

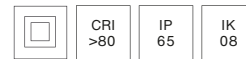

### Domino Clean Low UGR

Indispensable. Thanks to antiglare louvre it reduces glare and directs light precisely, providing comfort and uniformity as well as welcoming general lighting.

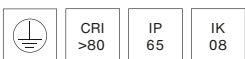

### Topaz ODG Clean AI

Efficient light combined with easy maintenance. Special construction of luminaire allows opening it from the top and avoiding littering.



### Topaz ODG Clean ST Smooth

Efficient luminaire with construction allowing opening it from the top and avoiding littering. Adapted to be walked on during maintenance.



Jolly Med, Warsaw, Poland







Rubin Clean-Eco **N**

- Operating theatres - surgery rooms
- Surroundings of operating theatres (clean corridors)
- Intensive care rooms (ICU)
- Post-surgery recovery rooms
- Blood extraction rooms
- Laparoscopic & Endoscopic procedure rooms
- Patient rooms
- Consultancy & Doctors rooms**
- Laboratories**
- Dermatology & Dental offices**
- Common areas: corridors, waiting areas
- Receptions
- Doctors common offices
- Research laboratory & Pharmaceutical laboratory
- Clean rooms
- Research laboratories with laminar chambers
- Research laboratories without laminar chambers
- Precision production
- Food industry
- Underground car parks
- Outdoors: gardens, car parks

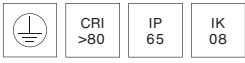

### Rubin Clean-Eco N

Surface-mounted internal luminaire for clean and medical facilities, characterised by high energy efficiency, long service life and versions with CRI>95, ensuring excellent colour rendering.

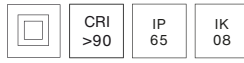
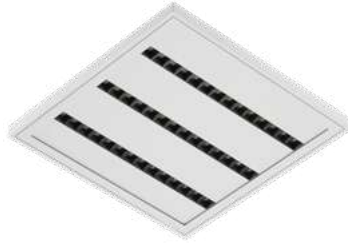

### Domino Clean N Surface Low UGR

High-efficiency surface-mounted luminaire designed for clean and medical environments, featuring advanced anti-glare louvers that ensure exceptional visual comfort and superior quality of light.



### Agat Clean-Eco

Luminaire designed to module suspended ceilings. Luminaire body made from steel sheet. Diffusers permanently mounted, no aluminium frame.

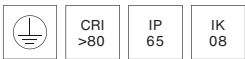

### Agat Clean

Luminaire designed to module and plasterboard suspended ceilings. Luminaire body made from steel sheet. Optical systems and diffusers mounted in an aluminium frame.

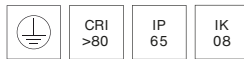

### Agat Clean LED Smooth

Luminaire designed to module and plasterboard suspended ceilings. Luminaire body made from steel sheet. The product ensures a homogeneous distribution of light.

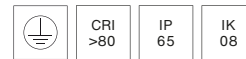
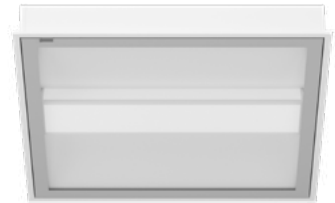

### Agat Clean Pos

LED luminaire designed to module and plasterboard suspended ceilings. Luminary design prevents from dazzle effect.

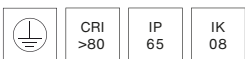

### Agat Clean Slight

Luminaire designed to module suspended ceilings. Light distribution made by using high performance lenses.



### Agat Clean No Frame

Luminaire designed to module and plasterboard suspended ceilings. Luminaire body made from steel sheet. Lack of aluminium frame.

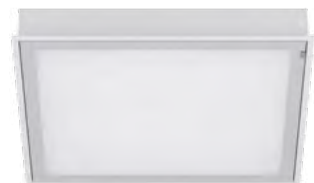

### Agat Clean TW

Luminaire designed to module and plasterboard suspended ceilings. Tunable White LED sources ensure providing patients and medical staff with most comfortable lighting conditions.

N New product

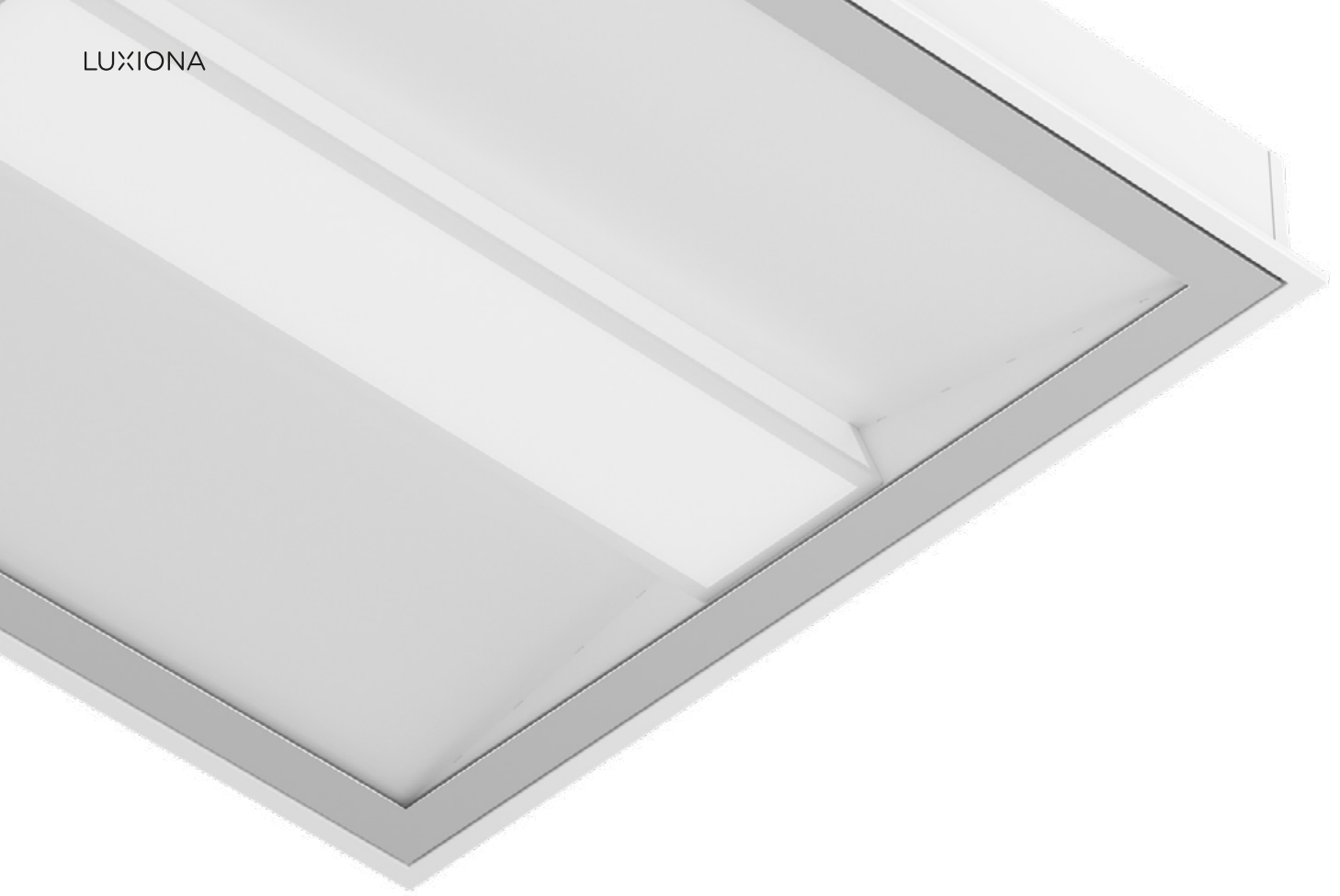

Rubin Clean Smooth

Operating theatres - surgery rooms

Surroundings of operating theatres (clean corridors)

Intensive care rooms (ICU)

Post-surgery recovery rooms

Blood extraction rooms

Laparoscopic & Endoscopic procedure rooms

Patient rooms

**Consultancy & Doctors rooms - continuation**

**Laboratories - continuation**

**Dermatology & Dental offices - continuation**

Common areas: corridors, waiting areas

Receptions

Doctors common offices

Research laboratory & Pharmaceutical laboratory

Clean rooms

Research laboratories with laminar chambers

Research laboratories without laminar chambers

Precision production

Food industry

Underground car parks

Outdoors: gardens, car parks



### Rubin Clean

Surface mounted luminaire. Luminaire body made from steel sheet. Diffusers and optical systems in aluminium frame.



### Rubin Clean Smooth

Surface mounted luminaire. Luminaire body made from steel sheet. The product ensures a homogeneous distribution of light.

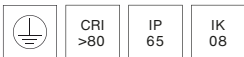
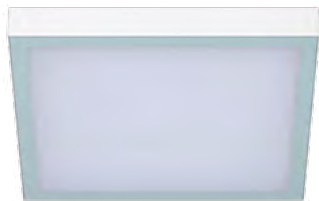

### Rubin Clean No Frame

Luminaire perfect for clean rooms. Without frame or visible elements joining the diffuser with luminaire's body it provides contamination-free conditions.



### Domino Clean

Indispensable. Thanks to antiglare louvre it reduces glare and directs light precisely, providing comfort and uniformity as well as welcoming general lighting.

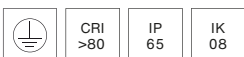

### Topaz ODG Clean AI

Efficient light combined with easy maintenance. Special construction of luminaire allows opening it from the top and avoiding littering.



### Topaz ODG Clean ST Smooth

Efficient luminaire with construction allowing opening it from the top and avoiding littering. Adapted to be walked on during maintenance.





Non-Invasive Medicine Centre, The University Clinical Centre, Gdansk. Poland





Beryl Surface LED K/L3

- Operating theatres - surgery rooms
- Surroundings of operating theatres (clean corridors)
- Intensive care rooms (ICU)
- Post-surgery recovery rooms
- Blood extraction rooms
- Laparoscopic & Endoscopic procedure rooms
- Patient rooms
- Consultancy & Doctors rooms
- Laboratories
- Dermatology & Dental offices

## **Common areas: corridors, waiting areas**

- Receptions
- Doctors common offices
- Research laboratory & Pharmaceutical laboratory
- Clean rooms
- Research laboratories with laminar chambers
- Research laboratories without laminar chambers
- Precision production
- Food industry
- Underground car parks
- Outdoors: gardens, car parks

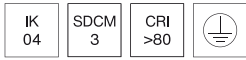

### Agat Slim

Versatile lighting, designed to manage light and to create comfortable view indoors. Luminaire made from powder-coated steel sheet, perfect for creating long lines.



### Snake V

Versatile lighting with a surprising twist. Luminaire combines comfortable lighting with creative appearance.



### Beryl New K

A perfect union between minimalism, elegance and simple shape. The luminaire has the ability to adjust the optics in two planes (in the vertical axis by 359° and to the left and right 15°).



### Beryl New O

Small, yet powerful. Luminaire perfectly aligned with a space's aesthetics, distinguished by high efficiency and minimum usage. Excellent heat dissipation and large luminous flux for its size.

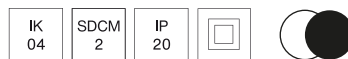

### Beryl Surface K

Downlight surface-mounted luminaire unrivaled in combining quality and energy efficiency. It has the ability to adjust the optics (in the vertical axis by 359° and to the left and right 15°).

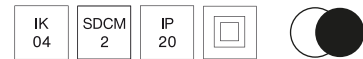

### Beryl Surface O

Efficient lighting to light up spaces with hardly noticeable effect on the environment and our comfort. Small visibility gives room for great visual ease for its users.

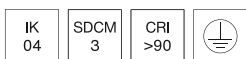

### Patos O

Architectural lighting that embodies an irreproachable style and high quality. With a circular design and soft light it subtly enhances the space and makes it more welcoming.



### Patos Line

Simple and elegant, designed for exceptional spaces that need individual character. Luminaire with a smooth or prismatic diffuser with exceptionally good light transmission.



### Versatile

Small size customisable downlight that comes in different lighting sources and combinable structures. Creates minimalist general lighting systems.



European Specialised Medical Centres – Korfantowska Orthopaedics and Rehabilitation KORT Ltd., Korfantow. Poland







X-Line Pro

- Operating theatres - surgery rooms
- Surroundings of operating theatres (clean corridors)
- Intensive care rooms (ICU)
- Post-surgery recovery rooms
- Blood extraction rooms
- Laparoscopic & Endoscopic procedure rooms
- Patient rooms
- Consultancy & Doctors rooms
- Laboratories
- Dermatology & Dental offices
- Common areas: corridors, waiting areas

## **Receptions**

- Doctors common offices
- Research laboratory & Pharmaceutical laboratory
- Clean rooms
- Research laboratories with laminar chambers
- Research laboratories without laminar chambers
- Precision production
- Food industry
- Underground car parks
- Outdoors: gardens, car parks



### X-Line Pro

A new, versatile product from the X-Line family, with a maximally simplified structure, without mounting plates or LED plates, distinguished by aluminium louvers with efficient LED sources.

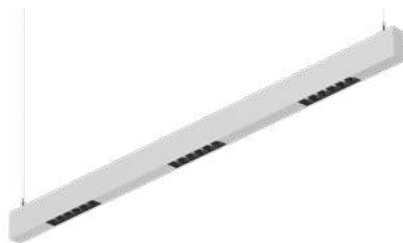

### X-Line Slight

New luminaire with a classic and elegant line. An aluminium profile with a minimised width up to 34mm wide, and a diffuser recessed into the body and aesthetically flushed with the equipment.

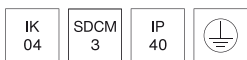

### Artshape Sq

A timeless design that provides creative lighting with the use of a square shape. With the possibility of painting according to RAL palette, it takes on diverse tasks in various spaces.



### Artshape Three

Best way to evade boredom. Luminaire combines modern design and functionality with creating a variety of unconventional accents. Available in Full and Edge versions.

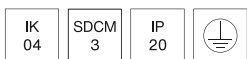

### Snake V

Versatile lighting with a surprising twist. Luminaire combines comfortable lighting with creative appearance.



### Flying Surface

A visionary eye-catcher. A proposal that arose from French designer **Jean Nouvel** and Troll's alliance. It gives the feeling of floating in space and provides even and balanced lighting.



Luxcan Pro

- Operating theatres - surgery rooms
- Surroundings of operating theatres (clean corridors)
- Intensive care rooms (ICU)
- Post-surgery recovery rooms
- Blood extraction rooms
- Laparoscopic & Endoscopic procedure rooms
- Patient rooms
- Consultancy & Doctors rooms
- Laboratories
- Dermatology & Dental offices
- Common areas: corridors, waiting areas

## **Receptions - continuation**

- Doctors common offices
- Research laboratory & Pharmaceutical laboratory
- Clean rooms
- Research laboratories with laminar chambers
- Research laboratories without laminar chambers
- Precision production
- Food industry
- Underground car parks
- Outdoors: gardens, car parks



### Luxcan Pro

A new product for different applications. Various optics, based on lenses, provide a wide range of possibilities, from the narrow beam, indirect, to the wide beam. Available with the possibility of ordering a non-standard version.



### Luxcan C

Most advanced LED light sources and variety of optics. Perfect as an accent lighting in places requiring distinction. Power supply placed in the adapter allows for a smaller size of the luminaire.



### Luxcan Mini

Small but strong. A classic luminaire with a perfect beam of light. Its power supply remains hidden by the rail, which decreases the luminaire's size.

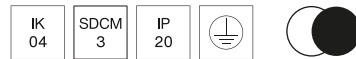

### Luxcan R

A cylindrical projector that seamlessly fits in any room. It combines advanced LED sources with a variety of optics perfect as an accent lighting in spaces that need a nice touch.



### Lumbo

Balance and harmony. Spherical reflector designed for avoiding the visual disproportion. Combines Premium White LED sources with high colour rendering index. 'Total Orientation System' allows it to rotate through 355° or tilt by 90°.

# REJESTRACJA

- < CHIRURGIA NACZYNIOWA
- < CHIRURGIA OGÓLNA
- < CHIRURGIA ONKOLOGICZNA
- < CHIRURGIA PLASTYCZNA
- < CHIRURGIA RĘKI
- < ORTOPEDIA
- < OTOLARYNGOLOGIA

ODDZIAŁ

LUTY





Polish Mother's Memorial Hospital Research Institute, Lodz. Poland



Gameta - Infertility Treatment Clinic, Kielce. Poland 73



X-Line Slight

- Operating theatres - surgery rooms
- Surroundings of operating theatres (clean corridors)
- Intensive care rooms (ICU)
- Post-surgery recovery rooms
- Blood extraction rooms
- Laparoscopic & Endoscopic procedure rooms
- Patient rooms
- Consultancy & Doctors rooms
- Laboratories
- Dermatology & Dental offices
- Common areas: corridors, waiting areas
- Receptions
- Doctors common offices**
- Research laboratory & Pharmaceutical laboratory
- Clean rooms
- Research laboratories with laminar chambers
- Research laboratories without laminar chambers
- Precision production
- Food industry
- Underground car parks
- Outdoors: gardens, car parks



### X-Line Pro

A versatile product from the X-Line family, with a maximally simplified structure, without mounting plates or LED plates, distinguished by aluminium louvers with efficient LED sources.

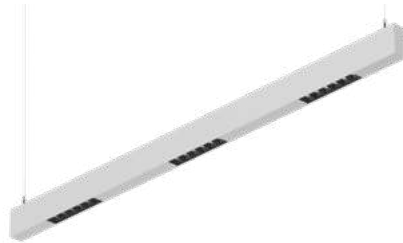

### X-Line Slight

A luminaire with a classic and elegant line. An aluminium profile with a minimised width up to 34mm wide, and a diffuser recessed into the body and aesthetically flushed with the equipment.



### Agat Pos

Comfort without the dazzle effect. Luminaire designed to module and suspended ceilings with optical system made of white reflectors.

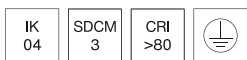
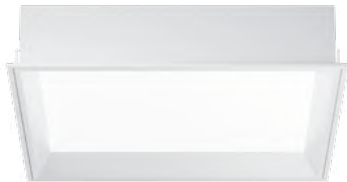

### Agat Deco Smooth

Gentle and mellow light. Luminaire brings the depth of the space to life and provides a uniform light as well as practical and lasting solutions.

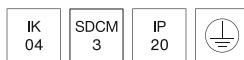

### Snake V

Versatile lighting with a surprising twist. Luminaire combines comfortable lighting with high efficiency and creative appearance.



### Europanel

Inconspicuous yet effective. Luminaire with efficient LED sources for a wide range of applications. A perfect solution that easily blends with its surroundings.



### Domino

Indispensable. Thanks to antiglare louvre it reduces glare and directs light precisely, providing comfort and uniformity as well as welcoming general lighting.



Agat Clean No Frame LED

Operating theatres - surgery rooms

Surroundings of operating theatres (clean corridors)

Intensive care rooms (ICU)

Post-surgery recovery rooms

Blood extraction rooms

Laparoscopic & Endoscopic procedure rooms

Patient rooms

Consultancy & Doctors rooms

Laboratories

Dermatology & Dental offices

Common areas: corridors, waiting areas

Receptions

Doctors common offices

## **Research laboratory & Pharmaceutical laboratory**

Clean rooms

Research laboratories with laminar chambers

Research laboratories without laminar chambers

Precision production

Food industry

Underground car parks

Outdoors: gardens, car parks



CLEAN CLASS 5-6	CRI >80	IP 65	IK 08
--------------------	------------	----------	----------

### Agat Clean Class 5-6

Comfortable light thanks to efficient optical systems and diffusers mounted in aluminium frame. Designed for module suspended ceilings.



CLEAN CLASS 5-6	CRI >80	IP 65	IK 08
--------------------	------------	----------	----------

### Agat Clean Class 5-6 No Frame

Top performance luminaire made of steel sheet, without an aluminium frame, which helps exclude unwanted contamination in clean rooms.



CLEAN CLASS 5-6	CRI >80	IP 65	IK 08
--------------------	------------	----------	----------

### Rubin Clean Class 5-6

Top performance surface mounted luminaire. Body made of steel sheet with optical systems and diffusers placed in aluminium frame.



CLEAN CLASS 5-6	CRI >80	IP 65	IK 08
--------------------	------------	----------	----------

### Rubin Clean Class 5-6 No Frame

Product dedicated to clean rooms with increased cleanliness class ISO 5-6. Designed for ceiling mounting and equipped with highly efficient LED panels. Available with a wide range of diffusers.

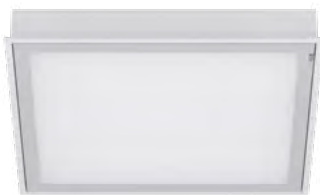

CLEAN CLASS 7-8-9	CRI >80	IP 65	IK 08
----------------------	------------	----------	----------

### Agat Clean Class 7-8-9

Highly efficient luminaire designed for module suspended ceilings. Optical systems and diffusers mounted in an aluminium frame.



CLEAN CLASS 7-8-9	CRI >80	IP 65	IK 08
----------------------	------------	----------	----------

### Rubin Clean Class 7-8-9

Top performance luminaire designed for surface mounting, with diffusers and optical systems placed in aluminium frame.



Rubin Clean LED

- Operating theatres - surgery rooms
- Surroundings of operating theatres (clean corridors)
- Intensive care rooms (ICU)
- Post-surgery recovery rooms
- Blood extraction rooms
- Laparoscopic & Endoscopic procedure rooms
- Patient rooms
- Consultancy & Doctors rooms
- Laboratories
- Dermatology & Dental offices
- Common areas: corridors, waiting areas
- Receptions
- Doctors common offices
- Research laboratory & Pharmaceutical laboratory

## **Clean rooms**

**Research laboratories with laminar chambers**

**Research laboratories without laminar chambers**

**Precision production**

**Food industry**

- Underground car parks
- Outdoors: gardens, car parks



CLEAN CLASS 3-4	CRI >80	IP 65	IK 08
--------------------	------------	----------	----------

### Agat Clean Class 3-4

Top performance thanks to highly efficient LED panels. Luminaire designed for module and cardboard suspended ceilings.



CLEAN CLASS 3-4	CRI >80	IP 65	IK 08
--------------------	------------	----------	----------

### Agat Clean Class 3-4 No Frame

The luminaire is intended for clean rooms with an increased ISO 3-4 cleanliness class. Designed for suspended modular ceilings, equipped with highly efficient LED panels. Available with a wide range of diffusers.



CLEAN CLASS 3-4	CRI >80	IP 65	IK 08
--------------------	------------	----------	----------

### Rubin Clean Class 3-4

Comfortable light thanks to efficient optical systems and diffusers mounted in aluminium frame. Designed for module suspended ceilings.



CLEAN CLASS 3-4	CRI >80	IP 65	IK 08
--------------------	------------	----------	----------

### Rubin Clean Class 3-4 No Frame

High protection from contamination thanks to lack of aluminium frame or visible elements joining the diffuser and the luminaire body.



CLEAN CLASS 7-8-9	CRI >80	IP 65	IK 08
----------------------	------------	----------	----------

### Agat Clean Class 7-8-9

Highly efficient luminaire designed for module suspended ceilings. Optical systems and diffusers mounted in an aluminium frame.



CLEAN CLASS 7-8-9	CRI >80	IP 65	IK 08
----------------------	------------	----------	----------

### Rubin Clean Class 7-8-9

Top performance luminaire designed for surface mounting, with diffusers and optical systems placed in aluminium frame.



CRI >80	IP 44	SDCM 3	
------------	----------	-----------	--

### Laminar LED

Streamlined, oval shape that makes it suitable for rooms with laminar flow ventilation. The air flowing around the luminaire is less susceptible to mechanical resistance. LED modules with color temperature 4000 K or with monochromatic yellow light.





Dr Irena Eris Cosmetics, Piaseczno. Poland



Production area for mechanical modules, Cleanroom, Eindhoven. Netherlands 81



Neptun V2

- Operating theatres - surgery rooms
- Surroundings of operating theatres (clean corridors)
- Intensive care rooms (ICU)
- Post-surgery recovery rooms
- Blood extraction rooms
- Laparoscopic & Endoscopic procedure rooms
- Patient rooms
- Consultancy & Doctors rooms
- Laboratories
- Dermatology & Dental offices
- Common areas: corridors, waiting areas
- Receptions
- Doctors common offices
- Research laboratory & Pharmaceutical laboratory
- Clean rooms
- Research laboratories with laminar chambers
- Research laboratories without laminar chambers
- Precision production
- Food industry

**Underground car parks**  
**Outdoors: gardens, car parks**

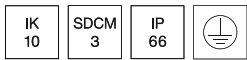

### Neptun V2

Tightly-closed ceiling luminaires, ensuring additional protection against solid body penetration and jet of water from all directions. Perfect to be installed in moist and dusty rooms.



### Numancia

Luminaire adds in an PMMA lens system. Tempered glass diffuser. Multiple optical distributions: 30°, 60°, 90° and narrow asymmetrical. Designed for wall or ceiling surface mounting.



### Beryl Proof Wall

An eye-catching, cylindrical luminaire that is suitable for mounting on walls, equipped with efficient LED sources. Perfect for decorative or accent lighting of building facades.

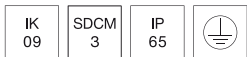

### Fasad

Highly effective luminaire resistant to all atmospheric conditions. Recommended for wall mounting or on top of solid surfaces. It will perfectly distinguish every architectural object.



### Tosca

Timeless design. Intended for installation on a hardened surface, equipped with high-performance, energy-saving LED sources of the latest generation.

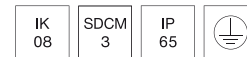

### Tosca Slim

Unobtrusive, elegant, and energysaving. Designed for installation on a hardened surface. Smaller diameter relative to the Tosca luminaire.



### Filar

A minimalist design and simple form. Base made of aluminium and the diffuser tube made of acrylic satin, perfectly complements surroundings of architectural buildings.



### Kubik LED

Ideal for selected outdoor spaces thanks to its elegant design and wide range of optical variants. Made in aluminium and powder paint to guarantee maximum resistance to weather conditions.



### Kubik 1D

Outdoor luminaire to be mounted on dedicated foundation. LED module is additionally sealed with a special lens which at the same time ensures optimal wide light distribution.



Kubik Pole L New

- Operating theatres - surgery rooms
- Surroundings of operating theatres (clean corridors)
- Intensive care rooms (ICU)
- Post-surgery recovery rooms
- Blood extraction rooms
- Laparoscopic & Endoscopic procedure rooms
- Patient rooms
- Consultancy & Doctors rooms
- Laboratories
- Dermatology & Dental offices
- Common areas: corridors, waiting areas
- Receptions
- Doctors common offices
- Research laboratory & Pharmaceutical laboratory
- Clean rooms
- Research laboratories with laminar chambers
- Research laboratories without laminar chambers
- Precision production
- Food industry
- Underground car parks

**Outdoors: gardens, car parks - continuation**



### Kubik Pole L New

Outdoor luminaire for assembling on a hardened surface equipped with the highly effective power saving LED sources of the newest generation. The system is designed and optimized for lighting streets, parks, gardens.



### Kubik Pole T New

Geometric T-shaped luminaire. Equipped with highly efficient, energy-saving LED sources with asymmetrical or symmetrical lenses, that provide uniform and functional lighting.



### Kubik Pole 4D

Simple geometric form and resistance in all conditions. Luminaire for mounting on a hard surface, equipped with an optical system for various applications.



### Kubik Pole

Outdoor luminaire for assembling on a hardened surface (concrete, sett or basement). IK09 strike resistant. Luminaire height: 300, 600, 900, 3000 and 4000 mm.



### Kubik Pole ODB

Outdoor luminaire for assembling on a hardened surface. LED sources are placed in the upper part of the luminaire, and hidden within the construction, invisible for a potential viewer.



### Kubik 2D

Luminaire intended for mounting on the dedicated foundation (version 900 mm) or directly on a paved basis (version 300 mm and 600 mm). LED the module is sealed with a special lens that equips luminaire with optimal wide light distribution.

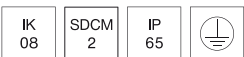

### Kubik Pole Soft

Luminaire equipped with the latest generation of efficient, energy-saving LED sources. Designed to illuminate pedestrian routes, equipped with PC opal diffuser. Provides complete protection against dust and water. Impact resistant - IK08.

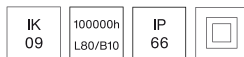

### Pareo One

Body made from aluminum cast. Transparent diffuser is made from polycarbonate which is highly resistant to mechanical factors – IK09.

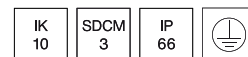

### Streetpark

Highly weather proof luminaire, equipped with adjustable handle designed for mounting on posts and arms. Lens optical system.

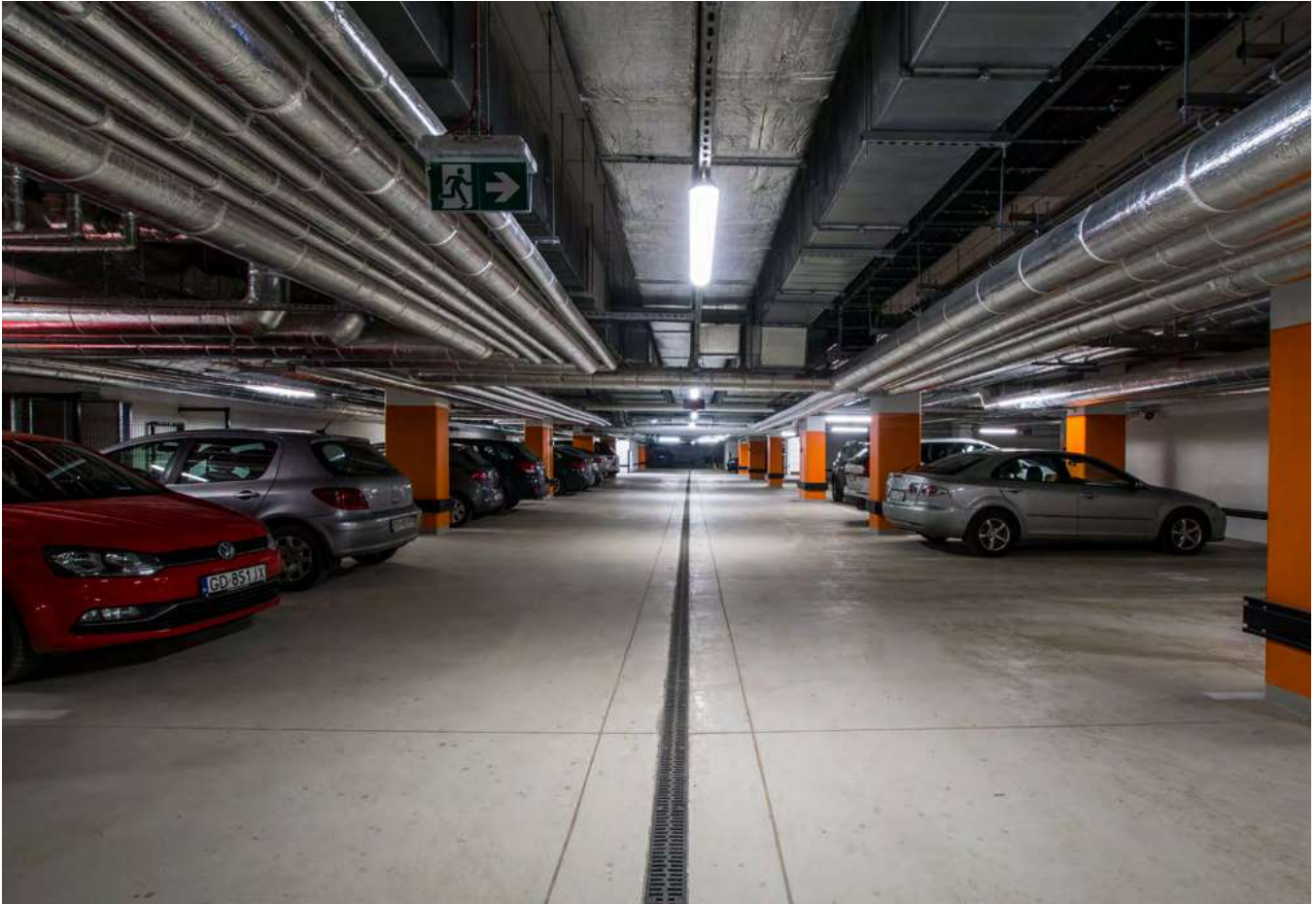

Non-Invasive Medicine Centre, The University Clinical Centre, Gdansk. Poland





UNIWERSYTET GDAŃSKI UNIWERSYTET MEDYCYNICZNY

# Selection of luminaires for hospitals

## Technical information summary

More standard versions available at [www.luxiona.com](http://www.luxiona.com)

Ask us for other variants different from those shown on our web in terms of light-gear-body.

### Agat Clean

Name	Luminaire luminous flux [lm]	Efficiency [lm/W]	Power of luminaire [W]	Colour temperature [K]	Dimensions [mm]
Agat Clean ISO LED CRI95	From 4707 to 12964	Up to 132,3	From 39,2 to 102,5	4000	596 x 596 x 76 1196 x 296 x 76 1196 x 596 x 76
Agat Clean ISO No Frame LED CRI95	From 4707 to 12552	Up to 128,1	From 39,2 to 102,5		596 x 596 x 67 1196 x 296 x 67 1196 x 596 x 67
Agat Clean LED Smooth	From 1914 to 11966	Up to 155,4	From 14 to 79	3000 4000	596 x 296 x 76 596 x 596 x 76 1196 x 296 x 76 1196 x 596 x 76

### Rubin Clean

Name	Luminaire luminous flux [lm]	Efficiency [lm/W]	Power of luminaire [W]	Colour temperature [K]	Dimensions [mm]
Rubin Clean ISO LED CRI95	From 4707 to 12964	Up to 132,3	From 39,2 to 102,5	4000	620 x 620 x 78 1210 x 310 x 78 1220 x 620 x 78
Rubin Clean ISO No Frame LED CRI95	From 4707 to 12552	Up to 128,1	From 39,2 to 102,5		574 x 574 x 69 1174 x 274 x 69 1174 x 574 x 69
Rubin Clean-ECO LED	From 2943 to 9713	Up to 160	From 20 to 61	4000 3000	620 x 620 x 85
Rubin Clean-ECO LED CRI95	From 4611 to 8605	Up to 127	From 40 to 67	4000 3000	620 x 620 x 85

### Agat Clinic

Name	Luminaire luminous flux [lm]	Efficiency [lm/W]	Power of luminaire [W]	Colour temperature [K]	Dimensions [mm]
Agat Clinic	all scenes	Up to 5086	Up to 88,6	3000 4000	595 x 595 x 130
	focused light	Up to 731	Up to 84		
	indirect light	Up to 922	Up to 68,3		
	direct light	Up to 3438	Up to 95		

### Domino Clean

Name	Luminaire luminous flux [lm]	Efficiency [lm/W]	Power of luminaire [W]	Colour temperature [K]	Dimensions [mm]
Domino Clean LOW UGR LED	From 5028 to 8039	Up to 167	From 36 to 48	3000 4000	592 x 592 x 50
Domino Clean Surface LOW UGR LED	From 5028 to 8039	Up to 167	From 36 to 48	3000 4000	645 x 645 x 40

**Topaz Clean**

Name	Luminaire luminous flux [lm]	Efficiency [lm/W]	Power of luminaire [W]	Colour temperature [K]	Dimensions [mm]
Topaz ODG Clean AL LED	From 2791 to 9246	Up to 152,4	From 20 to 61	3000	657 x 626 x 50-105
Topaz ODG Clean AL LED CRI95	From 4372 to 8191	Up to 120	From 40 to 67	4000	
Topaz ODG Clean ST LED Smooth	From 3828 to 9346	Up to 159	From 27 to 59	4000	650 x 650 x 55-75
Topaz ODG Clean ST LED Smooth CRI95	From 3510 to 8679	Up to 118	From 33 to 74	4000	

**Artshape**

Name	Luminaire luminous flux [lm]	Efficiency [lm/W]	Power of luminaire [W]	Colour temperature [K]	Dimensions [mm]
Artshape Round Small Edge	From 1492 to 23194	Consult us	From 25 to 76	3000	Ø650 x 85
Artshape Round Medium Edge			From 35 to 150		4000
Artshape Round Large Edge			From 50 to 245	TW	Ø1200 x 85
Artshape X			31 & 62		726 x 1000 x 80

**Beryl New**

Name	Luminaire luminous flux [lm]	Efficiency [lm/W]	Power of luminaire [W]	Colour temperature [K]	Dimensions [mm]
Beryl New LED O-1	From 852 to 4982	Up to 129,6	9,8 & 12,8	3000	Ø100 x 75
Beryl New LED O-2			From 16 to 25,5	4000	Ø165 x 100
Beryl New LED O-3			From 18,4 to 39,3	TW	Ø195 x 110

**Domino**

Name	Luminaire luminous flux [lm]	Efficiency [lm/W]	Power of luminaire [W]	Colour temperature [K]	Dimensions [mm]
Domino LOW UGR LED	From 542 to 7423	Up to 146,8	From 12,7 to 50,6	3000 4000	596 x 75 x 50
					596 x 296 x 23
					596 x 596 x 23
					1196 x 296 x 23
					1196 x 75 x 50
Domino LOW UGR LED Recessed			From 5,6 to 13		150 x 150 x 43 250 x 250 x 43

**Luxcan**

Name	Luminaire luminous flux [lm]	Efficiency [lm/W]	Power of luminaire [W]	Colour temperature [K]	Dimensions [mm]
Luxcan C 15° CRI>80	From 1430 to 3602	Up to 140,9	12,8 18,8 26,4	3000 4000	Ø85 x 205
Luxcan C 15° CRI>90					
Luxcan C 40° CRI>80					
Luxcan C 40° CRI>90					
Luxcan C 60° CRI>80					
Luxcan C 60° CRI>90					
Luxcan R 13°	From 1611 to 4241	Up to 129,2	From 12,8 to 33,1	4000	Ø108 x 210
Luxcan R 36°					
Luxcan R 60°					

**Patos**

Name	Luminaire luminous flux [lm]	Efficiency [lm/W]	Power of luminaire [W]	Colour temperature [K]	Dimensions [mm]		
Patos-Line	From 899 to 14196	Up to 129,3	From 9 to 35,3	3000 4000 TW	566 x 77 x 81		
					1126 x 77 x 81		
					1406 x 77 x 81		
					1686 x 77 x 81		
Patos O30						From 13 to 169	Ø324 x 150
Patos O45							Ø472 x 150
Patos O65							Ø672 x 150
Patos O80 LED							Ø822 x 164
Patos O100 LED				Ø1022 x 164			
Patos O120 LED				Ø1222 x 164			

## Filar

Name	Luminaire luminous flux [lm]	Efficiency [lm/W]	Power of luminaire [W]	Colour temperature [K]	Dimensions [mm]
Filar LED	From 2933 to 5867	Consult us	63 & 125	4000	300 x 300 x 2545 300 x 300 x 3045

## Beryl Proof Wall

Name	Luminaire luminous flux [lm]	Efficiency [lm/W]	Power of luminaire [W]	Colour temperature [K]	Dimensions [mm]
Beryl Proof Wall LED Up&Down Narrow	From 1110 to 3959	Up to 168,9	From 8,9 to 25,2	3000 4000	210 x 120 x 370
Beryl Proof Wall LED Up&Down Medium					
Beryl Proof Wall LED Up&Down Wide					
Beryl Proof Wall LED Up Or Down Narrow					
Beryl Proof Wall LED Up Or Down Medium					
Beryl Proof Wall LED Up Or Down Wide					

## Kubik

Name	Luminaire luminous flux [lm]	Efficiency [lm/W]	Power of luminaire [W]	Colour temperature [K]	Dimensions [mm]
Kubik Pole 4D	From 2411 to 5037	Up to 140,3	18,4 25,4 39,3	4000	220 x 220 x 1100 220 x 220 x 3000
Kubik New Pole T	From 10367 to 23045	Up to 146	From 78 to 157	5700	1629 x 120 x 3000 1629 x 120 x 4000 1629 x 120 x 5000
Kubik LED 1x1,7W 24°	From 103 to 1062	Up to 140,3	3	3000 4000 6500	100 x 100 x 94
Kubik LED 1x1,7W 5°-21°			3		100 x 100 x 94
Kubik LED 1x2,4W 24°			4		100 x 100 x 94
Kubik LED 1x2,4W 5°-21°			4		100 x 100 x 94
Kubik LED 1x7,2W 24°			9		150 x 150 x 135
Kubik LED 1x7,2W 5°-21°			9		150 x 150 x 135
Kubik LED 2x1,7W 24°			5		100 x 100 x 94
Kubik LED 2x1,7W 5°-21°			5		100 x 100 x 94
Kubik LED 2x2,4W 24°			7		100 x 100 x 94
Kubik LED 2x2,4W 5°-21°			7		100 x 100 x 94
Kubik LED 2x7,2W 5°-21°			18		150 x 150 x 135
Kubik LED 3x1,7W 24°			7		100 x 100 x 94
Kubik LED 3x1,7W 5°-21°			7		100 x 100 x 94
Kubik LED 3x2,4W 24°			9		100 x 100 x 94
Kubik LED 3x2,4W 5°-21°			9		100 x 100 x 94
Kubik LED 4x1,7W 24°			10		100 x 100 x 94
Kubik LED 4x1,7W 5°-21°			10	100 x 100 x 94	

# Selection of luminaires for clean manufactory

## Technical information summary

More standard versions available at [www.luxiona.com](http://www.luxiona.com)

Ask us for other variants different from those shown on our web in terms of light-gear-body.

### Agat Clean

Name	Luminaire luminous flux [lm]	Efficiency [lm/W]	Power of luminaire [W]	Colour temperature [K]	Dimensions [mm]
Agat Clean Class LED	From 1865 to 15261	Up to 156,8	From 13 to 97	3000 4000	596 x 596 x 76 1196 x 296 x 76 1196 x 596 x 76
Agat Clean Class No Frame LED	From 1865 to 15261	Up to 156,8	From 13 to 97	3000 4000	596 x 596 x 67 1196 x 296 x 67 1196 x 596 x 67

### Rubin Clean

Name	Luminaire luminous flux [lm]	Efficiency [lm/W]	Power of luminaire [W]	Colour temperature [K]	Dimensions [mm]
Rubin Clean Class LED	From 2791 to 15261	Up to 156,4	From 20 to 97	3000 4000	620 x 620 x 78 1210 x 310 x 78 1220 x 620 x 78
Rubin Clean Class No Frame LED	From 2791 to 15261	Up to 156,4	From 20 to 97	3000 4000	574 x 574 x 69 1174 x 274 x 69 1174 x 574 x 69

### Artshape

Name	Luminaire luminous flux [lm]	Efficiency [lm/W]	Power of luminaire [W]	Colour temperature [K]	Dimensions [mm]
Artshape Round Small Edge	From 1492 to 23194	Consult us	From 25 to 76	3000 4000 TW	Ø650 x 85
Artshape Round Medium Edge			From 35 to 150		Ø900 x 85
Artshape Round Large Edge			From 50 to 245		Ø1200 x 85
Artshape X			31 & 62		726 x 1000 x 80

### Beryl New

Name	Luminaire luminous flux [lm]	Efficiency [lm/W]	Power of luminaire [W]	Colour temperature [K]	Dimensions [mm]
Beryl New LED O-1	From 852 to 4982	Up to 129,6	9,8 & 12,8	3000	Ø100 x 75
Beryl New LED O-2			From 16 to 25,5	4000	Ø165 x 100
Beryl New LED O-3			From 18,4 to 39,3	TW	Ø195 x 110

### Domino

Name	Luminaire luminous flux [lm]	Efficiency [lm/W]	Power of luminaire [W]	Colour temperature [K]	Dimensions [mm]
Domino LOW UGR LED	From 542 to 7423	Up to 146,8	From 12,7 to 50,6	3000 4000	596 x 75 x 50
					596 x 296 x 23
					596 x 596 x 23
					1196 x 296 x 23
					1196 x 75 x 50
Domino LOW UGR LED Recessed			From 5,6 to 13		150 x 150 x 43
					250 x 250 x 43

## Luxcan

Name	Luminaire luminous flux [lm]	Efficiency [lm/W]	Power of luminaire [W]	Colour temperature [K]	Dimensions [mm]
Luxcan C 15° CRI>80	From 1430 to 3602	Up to 140,9	12,8 18,8 26,4	3000 4000	Ø85 x 205
Luxcan C 15° CRI>90					
Luxcan C 40° CRI>80					
Luxcan C 40° CRI>90					
Luxcan C 60° CRI>80					
Luxcan C 60° CRI>90	From 1611 to 4241	Up to 129,2	From 12,8 to 33,1	4000	Ø108 x 210
Luxcan R 13°					
Luxcan R 36°					
Luxcan R 60°					

## Patos

Name	Luminaire luminous flux [lm]	Efficiency [lm/W]	Power of luminaire [W]	Colour temperature [K]	Dimensions [mm]
Patos-Line	From 899 to 14196	Up to 129,3	From 9 to 35,3	3000 4000 TW	566 x 77 x 81
					1126 x 77 x 81
					1406 x 77 x 81
					1686 x 77 x 81
Patos O30			From 13 to 169		Ø324 x 150
Patos O45					Ø472 x 150
Patos O65					Ø672 x 150
Patos O80 LED					Ø822 x 164
Patos O100 LED					Ø1022 x 164
Patos O120 LED					Ø1222 x 164

## Filar

Name	Luminaire luminous flux [lm]	Efficiency [lm/W]	Power of luminaire [W]	Colour temperature [K]	Dimensions [mm]
Filar LED	From 2933 to 5867	Consult us	63 & 125	4000	300 x 300 x 2545 300 x 300 x 3045

## Beryl Proof Wall

Name	Luminaire luminous flux [lm]	Efficiency [lm/W]	Power of luminaire [W]	Colour temperature [K]	Dimensions [mm]
Beryl Proof Wall LED Up&Down Narrow	From 1110 to 3959	Up to 168,9	From 8,9 to 25,2	3000 4000	210 x 120 x 370
Beryl Proof Wall LED Up&Down Medium					
Beryl Proof Wall LED Up&Down Wide					
Beryl Proof Wall LED Up Or Down Narrow					
Beryl Proof Wall LED Up Or Down Medium					
Beryl Proof Wall LED Up Or Down Wide					

**Kubik**

Name	Luminaire luminous flux [lm]	Efficiency [lm/W]	Power of luminaire [W]	Colour temperature [K]	Dimensions [mm]
Kubik Pole 4D	From 2411 to 5037	Up to 140,3	18,4 25,4 39,3	4000	220 x 220 x 1100 220 x 220 x 3000
Kubik New Pole T	From 10367 to 23045	Up to 146	From 78 to 157	5700	1629 x 120 x 3000 1629 x 120 x 4000 1629 x 120 x 5000
Kubik LED 1x1,7W 24°	From 103 to 1062	Up to 140,3	3	3000 4000 6500	100 x 100 x 94
Kubik LED 1x1,7W 5°-21°			3		100 x 100 x 94
Kubik LED 1x2,4W 24°			4		100 x 100 x 94
Kubik LED 1x2,4W 5°-21°			4		100 x 100 x 94
Kubik LED 1x7,2W 24°			9		150 x 150 x 135
Kubik LED 1x7,2W 5°-21°			9		150 x 150 x 135
Kubik LED 2x1,7W 24°			5		100 x 100 x 94
Kubik LED 2x1,7W 5°-21°			5		100 x 100 x 94
Kubik LED 2x2,4W 24°			7		100 x 100 x 94
Kubik LED 2x2,4W 5°-21°			7		100 x 100 x 94
Kubik LED 2x7,2W 5°-21°			18		150 x 150 x 135
Kubik LED 3x1,7W 24°			7		100 x 100 x 94
Kubik LED 3x1,7W 5°-21°			7		100 x 100 x 94
Kubik LED 3x2,4W 24°			9		100 x 100 x 94
Kubik LED 3x2,4W 5°-21°			9		100 x 100 x 94
Kubik LED 4x1,7W 24°			10		100 x 100 x 94
Kubik LED 4x1,7W 5°-21°			10		100 x 100 x 94





F. Muller Dental-Technik, Berlin. Germany



F. Muller Dental-Technik, Berlin. Germany 95



Sant Joan de Reus Hospital. Spain





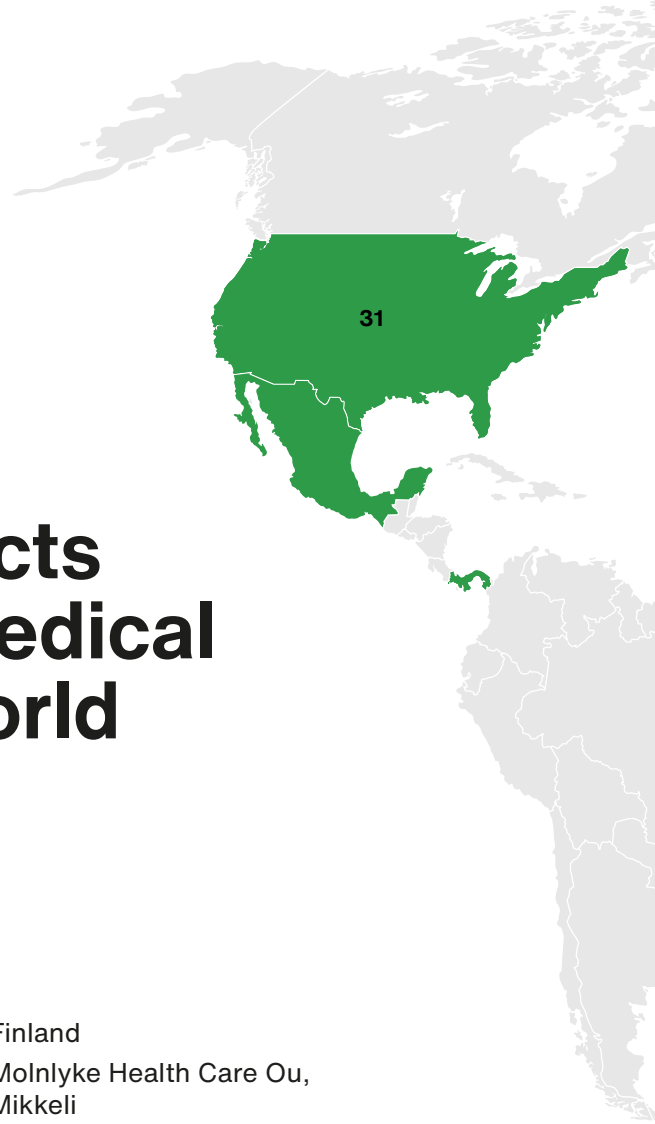

## Chosen projects for Clean & Medical around the world

1. Austria  
Landeskrankenhaus Hainburg
2. Azerbaijan  
1340 Baku
3. Belarus  
5th City Hospital
4. Belgium  
Greif Cleanroom, Izegem
5. China  
Crown Tech, Xinjiang Province
6. Croatia  
KBC Osijek  
Hospital Našice  
Hospital Koprivnica
7. Denmark  
Glostrup Apotek, Glostrup  
Philips Medisize Cleanroom, Struer
8. Estonia  
Private Clinic in Nomme, Tallin  
Tartu Hospital
9. Finland  
Molnlycke Health Care Oyj, Mikkeli  
Laboratory, Mikkeli  
Biocity Laboratory, Turku
10. France  
Strasbourg University Hospitals  
Centre Hospitalier Intercommunal, Castres  
Hospital Centre Laennec, Creil
11. Germany  
Martini Klinik, Hamburg  
Bayer Covestro Folienfabrik, Dormagen  
Krankenhaus Stuttgart  
Klinikum Charité Benjamin Franklin, Berlin  
Böhringer Ingelheim microParts GmbH, Dortmund  
Intuitive Surgical GmbH, Freiburg

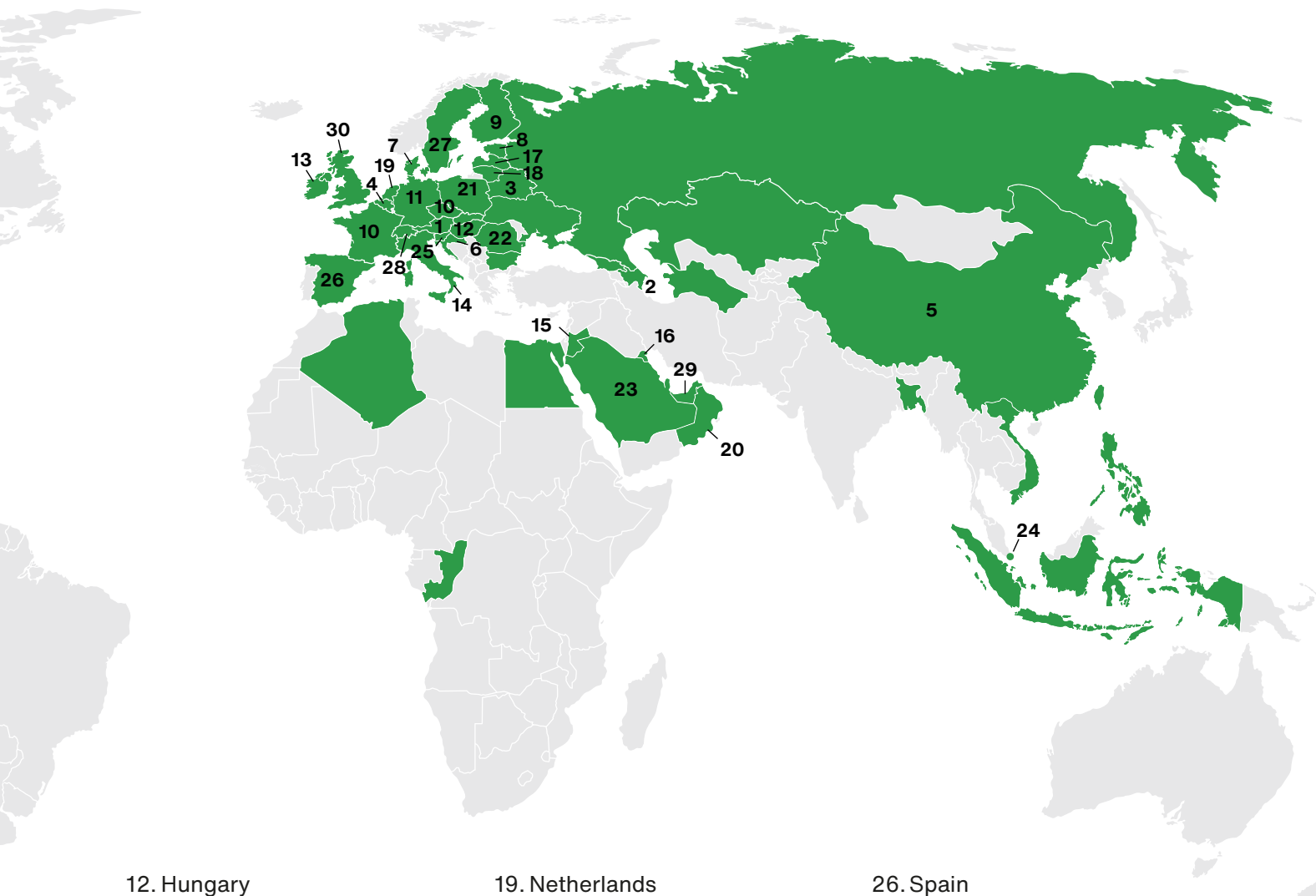

- |   |   |   |
|---|---|---|
| 12. Hungary<br>DSA Laboratory, Pecs<br>Medicover Clinic, Budapest<br>Flisom Hungary KFT,<br>Kecskemét | 19. Netherlands<br>Mechatronics Cleanroom<br>Laboratory, Eindhoven<br>Sint Maartenskliniek,<br>Nijmegen                   | 26. Spain<br>Mutua de Granollers,<br>Barcelona<br>Sant Joan de Reus Hospital<br>Nu Clinic Sant Cugat,<br>Barcelona<br>Grifols<br>Almirall<br>Institut Oncològic<br>de Barcelona |
| 13. Ireland<br>Carten Controls, Waterford<br>AQF Medical - Cleanroom,<br>Meath                        | 20. Oman<br>Muscat - Royal Expansion<br>Mouwasat Hospital   | 27. Sweden<br>APL Cleanroom, Gothenburg<br>Carballo Klinik  |
| 14. Italy<br>Veneto Vidas Hospitals, Milan  | 21. Poland<br>GlaxoSmithKline<br>Pharmaceuticals, Poznan<br>Hybrid OR, Olsztyn<br>Non-invasive Medicine<br>Centre, Gdansk | 28. Switzerland<br>St. Clarashospital Basel   |
| 15. Jordan<br>Al Kindl  | 22. Romania<br>Hospital Bagdasar,<br>Bucharest<br>Polaris Clinic, Cluj-Napoca   | 29. United Arab Emirates<br>Dubai Showroom  |
| 16. Kuwait<br>Chest Hospital Kuwait<br>Jaah Hospital  | 23. Saudi Arabia<br>Saudi Arabien Medinah<br>Hospital   | 30. United Kingdom<br>Noumed Life Sciences,<br>Maidenhead<br>Coca Colla Lisburn<br>Roodlane Medical Clinique,<br>London   |
| 17. Latvia<br>Stradina Hospital, Riga<br>Liepajas Regional Hospital<br>Riga 1st Hospital              | 24. Singapur<br>NCID Singapur   | 31. USA<br>Kite Pharma, Washington  |
| 18. Lithuania<br>Affidea Clinic, Vilnius<br>Odonthology Clinic, Alytus<br>Pilenu Klinika, Marijampole | 25. Slovenia<br>TIK Kobarid<br>University of Ljubljana<br>(clean room)  |   |

# LUXIONA worldwide



## Commercial offices:

Spain, Poland, France, Italy,  
Germany

## Logistics centre:

Spain

## Production:

Poland / Spain (emergency)

## LUXIONA

### LUXIONA Headquarters

C/ Diputació, 180, 4A  
08011 Barcelona  
Spain  
+34 938 466 909  
info@luxiona.com

### Spain

C/ Diputació, 180, 4A  
08011 Barcelona  
Spain  
+34 938 466 909  
info@luxiona.com

### Germany

Berlin Leuchtenfabrik,  
Haus A / 1. Etage  
Edisonstr. 63  
12459 Berlin, Germany  
+49 3040 535 600  
info@luxiona.de

### France

7 Rue Colonel Chambonnet  
69500 Bron  
France  
+33 472 146 666  
info.france@luxiona.com

### Marketing

marketing@luxiona.com

luxiona.com

support@luxiona.com

### Poland

ul. Komitetu Obrony Robotników 48  
02-146 Warszawa  
Poland  
+48 22 721 72 72  
info.poland@luxiona.com

### Italy

Via Luigi Cadamosto 4  
26900 Lodi (LO)  
Italy  
+39 0 298 274 010  
info.italy@luxiona.com

### Export

Export Department  
+48 505 695 638  
customer.care@luxiona.com

### Purchasing

globalpurchasing@luxiona.com

[Linkedin.com/company/luxiona](https://www.linkedin.com/company/luxiona)  
 [Facebook.com/luxionagroup](https://www.facebook.com/luxionagroup)  
 [Instagram.com/luxionagroup](https://www.instagram.com/luxionagroup)  
 [YouTube: LUXIONA Group](https://www.youtube.com/LUXIONA%20Group)



