



Workplace Lighting

LUXIONA

EN

Index

2	Personalised solutions and European design
8	Sustainable solutions. Innovative technology
9	Customise and go beyond the standards
26	Human Centric Lighting
27	Lighting your office together with LUXIONA
29	New sound absorbent solutions
31	Lighting solutions for every space
72	Selection of luminaires
80	LUXIONA worldwide
80	Contact

LUXIONA



Our values

European design, customised solutions and competitive edge

Created in Barcelona, Spain, and developed in Poland, our products combine European design with high quality and efficiency. At the very centre of our work is our passion for lighting and functional design. The superior performance aligned with aesthetics and simplicity of installation and maintenance makes it a perfect

solution for any space. Thanks to a variety of customisable options, it is possible to adjust our products to the needs of a specific project, including all kinds of spaces in retail facilities and offices, as well as architectural, public, outdoor, medical, and industrial spaces.



Design

Designed in Barcelona

From the moment we started our company in Barcelona in 1929, the value of design has been part of LUXIONA's soul. Since the invention of the first electrified track system inspired by the trolleybuses on the streets of Barcelona, the source of inspiration for our products is based on this city that exudes design, art, and the avant-garde. We have an international presence with offices in Spain, France,

Italy, Germany, and Poland, but it is here in Barcelona where the research and product development team is located to keep the initial spirit alive in each of our luminaires, always at the cutting edge of sustainable technologies. The result is lighting solutions that offer a comfortable visual experience, which enhances your well-being while respecting the environment.



DESIGN **PLUS**

Lighting Consulting

Our team of 50+ experts is always available in each country of our presence and will support you in your lighting projects. We provide personalised, advice specific to office spaces, based on experience and the know-how we have gained throughout the years. By fully monitoring your project through to implementation, we offer you a global and integral vision at every stage. A personal approach to every client is at the centre of our work and leads to a partnerships that result in top-quality projects.



Customer and project requirements

Stage 1: Plan including (suggestions for) the placement of luminaires. Detailed plans with sections, cuts, ceiling types, and furnishings. Functions, branding, ambience, experience, sensations, levels, and creation of environments. BIM methodology.



Lighting consulting, conceptualisation and development of the project Analysis and review of your plans and needs

Stage 2: Concept sketch of the lighting design. Plans with recommended placement of luminaires. Lighting design and calculations (3D modelling). Calculations to adjust and approve the (final) lighting design and the lighting levels, sensations, consumption control, and efficiency. Development of special projects and products.



Presentation and delivery of the project

Stage 3: Lighting levels represented in false colours. Luminaire placement plan (PDF and CAD). Technical data sheets of the applied products. Control and Smart Lighting services: Creation of groups and scenes, location of sensors, sketches and electrical diagrams, configuration, etc.



Technical support and customer service

Stage 4: The final lighting simulation project. Follow-up and supervision of installation and configurations. Incident management. Maintenance and repairs. Programming and commissioning of regulation and control systems.



Sustainable solutions

Sustainability is at the very core of our values. By working together we strive to develop projects that have a positive impact on the environment and promote a more sustainable lighting industry. We are able to achieve this by putting the control of the lighting in the hands of the user by using intelligent switching control systems and by providing users with efficient, and sustainable

solutions. One of them are LED sources used in LUXIONA luminaires, characterised by a long lifespan of 100,000 h and the LxBy parameter at the L80B10 level. This means that after 100,000 hours of use, the LED sources will retain 80% of their initial luminous flux, and only 10% of the LEDs will have less than 80% of their initial luminous flux. This means that we can enjoy their quality longer.

Innovative technology

Innovations and functionality have always been and will remain an important factor in the development of new lighting solutions, services, and the application of new technologies. The know-how accumulated after almost half a century of experience and the combination of design and engineering allows us to stay

one step ahead. Together with our R+D+i department, in constant search for new lighting solutions, we are able to use the latest generation of materials and production processes. Looking to the future combined with our experience allow us to shape the lighting of the future and expand our innovative product portfolio.



Certification programmes for green buildings



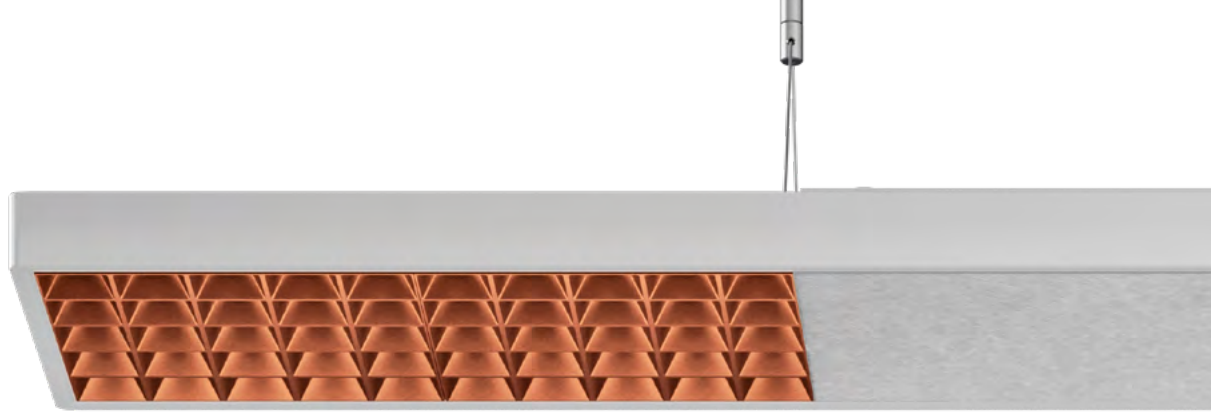

Customise and go beyond the standards

We leave nothing to chance. By listening, understanding, and combining our knowledge and experience we make the most of available possibilities. By anticipating the expectations of architects, lighting designers, interior designers, and engineers we create lighting solutions that respond to their needs.

Tailor-made lighting is the most effective way to address specific design challenges. From modern receptions, office rooms, coworking areas, meeting points and chill zones to big open spaces and conference rooms customizable lighting provides effective solutions and provides an inspiring, one-of-a-kind aesthetic. As a lighting manufacturer with an R&D department and modern technological facilities, we are creating non-standard solutions by modifying all parts of our luminaires: light, gear, and luminaire body. The result? Artisanal, made-to-measure solutions that fit settings intimate or expansive, functional or multipurpose.



Light

Colour temperature

From warm to cool, reproduces the sunlight tone during the day. Customised to create different atmospheres.

Colour rendering

Artificial light property to reproduce the real colours of an object. Key when product appearance is a must.

Lumen

Amount of visual light emitted.

Diffuser

Part of the luminaire with light and mechanical properties. A wide choice to control the emission and protect the luminaire.

Optic

The way the light is directed. Managing reflections and refractions to have most of light where is needed.

Emission

Optimising light output not only to achieve best performance but also comfort and wellness. Direct, undirect and Up&Down.



Gear

Control

On/off, dim light on request.

Endurance

Adapt lifespan to project needs even in hard conditions.

Emergency

Safety by lighting even when there is no electrical supply.

Sensors

Interaction in realtime between lighting and application environment.



Body

Size

Dimension adjusted to specific project.

Material

Sheet steel, aluminium, stainless steel, polycarbonate. Protection: IP, IK.

Acoustic material

Utilizing PET-based materials in acoustic luminaires reduces noise pollution and curbs sound wave reverberations and reflections, leading to heightened speech clarity and a tranquil auditory environment.

Finishing

Anodising, painting - with non-standard colours available in our offer, it's possible to choose any colour from the RAL palette, so it perfectly complements the character of the designed space.

Installation

Surface, recessed, suspended - it is also possible to adapt the design of the luminaires to various types of suspended ceilings used on the market, including ceilings with different module sizes.

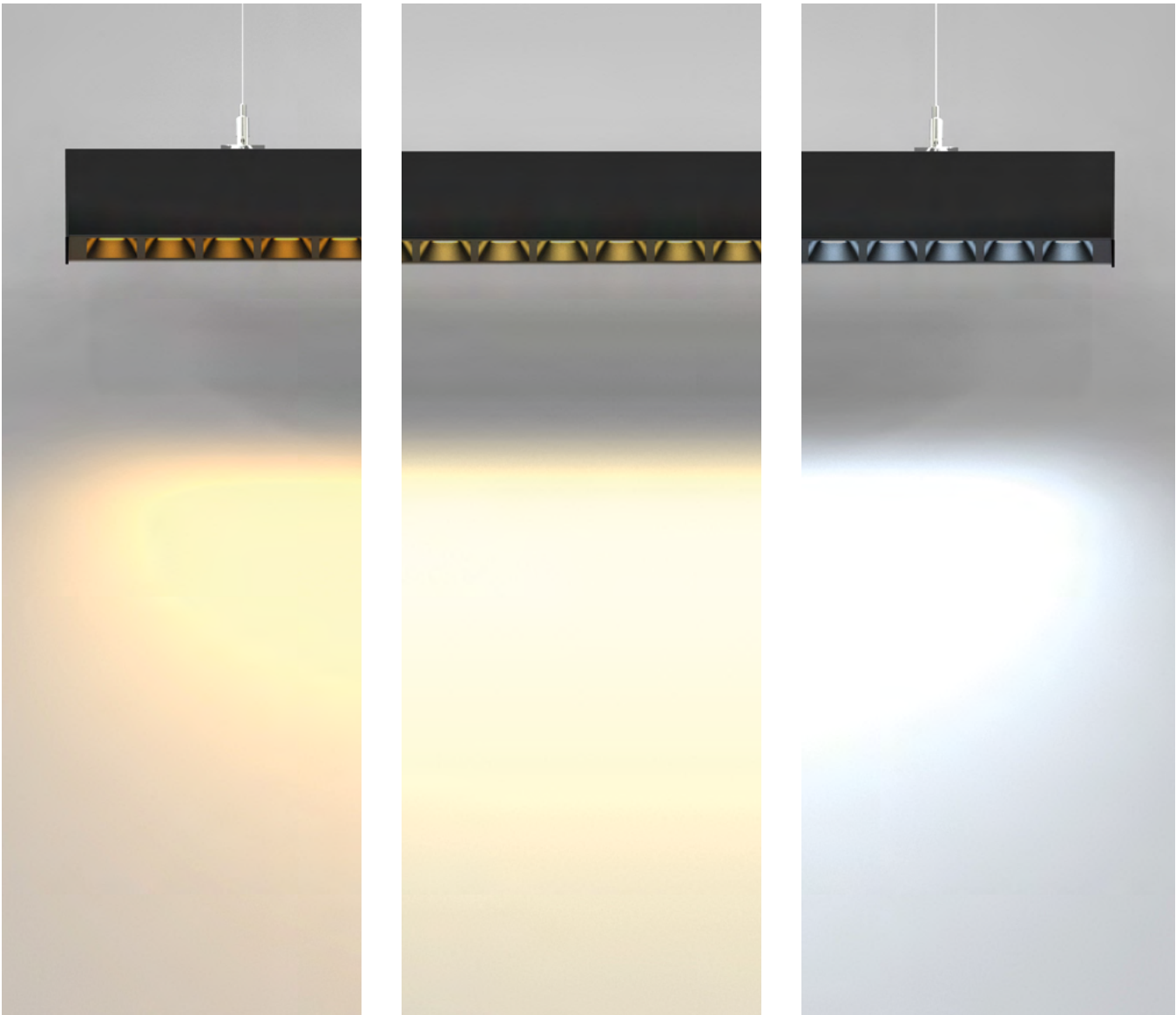

Customised light

Matching the LED light sources to the needs of the project or investor can require luminaires equipped with non-standard light sources, for example with a very warm colour of 2700 K, or with Tunable White light sources. Tunable White sources provide wide range of colour

temperatures, usually from 2700 to 6500 K. Tunable White is able to imitate the outdoor natural light but also to create artificial atmospheres that invites to calm or boost activity if needed.



Luxcan Pro



Adjust the luminaire's luminous flux to achieve the ideal light intensity and its uniformity. Select the luminaire with the appropriate light distribution to easily meet the required lighting standards.

Correct beam angle will help achieve the appropriate level of average illuminance and its uniformity by using luminaires with lower energy consumption. The right optical control provides comfort for optimal working spaces. This means savings for the investor when purchasing luminaires as well as lowering the cost of operating the lighting. Correct optical system allows

reducing glare, to meet the standard in offices (UGR <19). To achieve this, choose a product with Micro-PRM or a luminaire with an anti-glare louver.

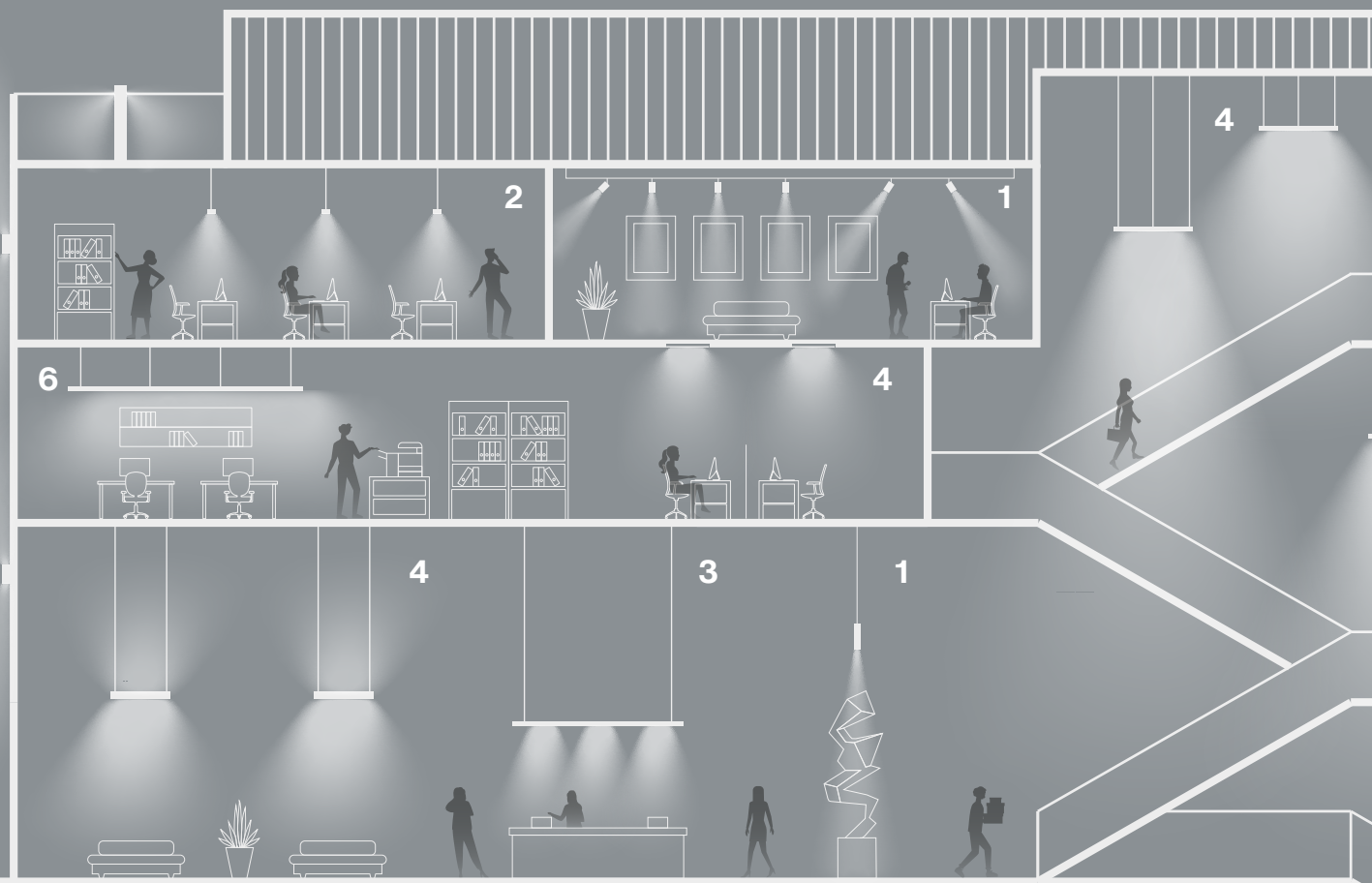

Solutions tailored to any space

The full availability of product families with customisable optical systems enables a wide variety of light distribution and helps to comply with lighting standards and investor requirements. We are aware that in some projects standard solutions will not be enough that's why we are open to create new personalised solutions. Our experience helps us do it regardless of how challenging the project may seem. LUXIONA luminaires offer contains a

variety of customisable options that are perfect for lighting any space in modern offices. Choosing aesthetic and functional lighting was never that simple and creative. Starting from classic office rooms, open spaces, through conference rooms, chill-out zones, corridors and staircases to sanitary rooms or underground garages - there are endless possibilities to create and personalise.

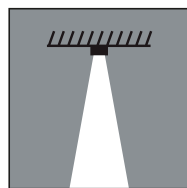
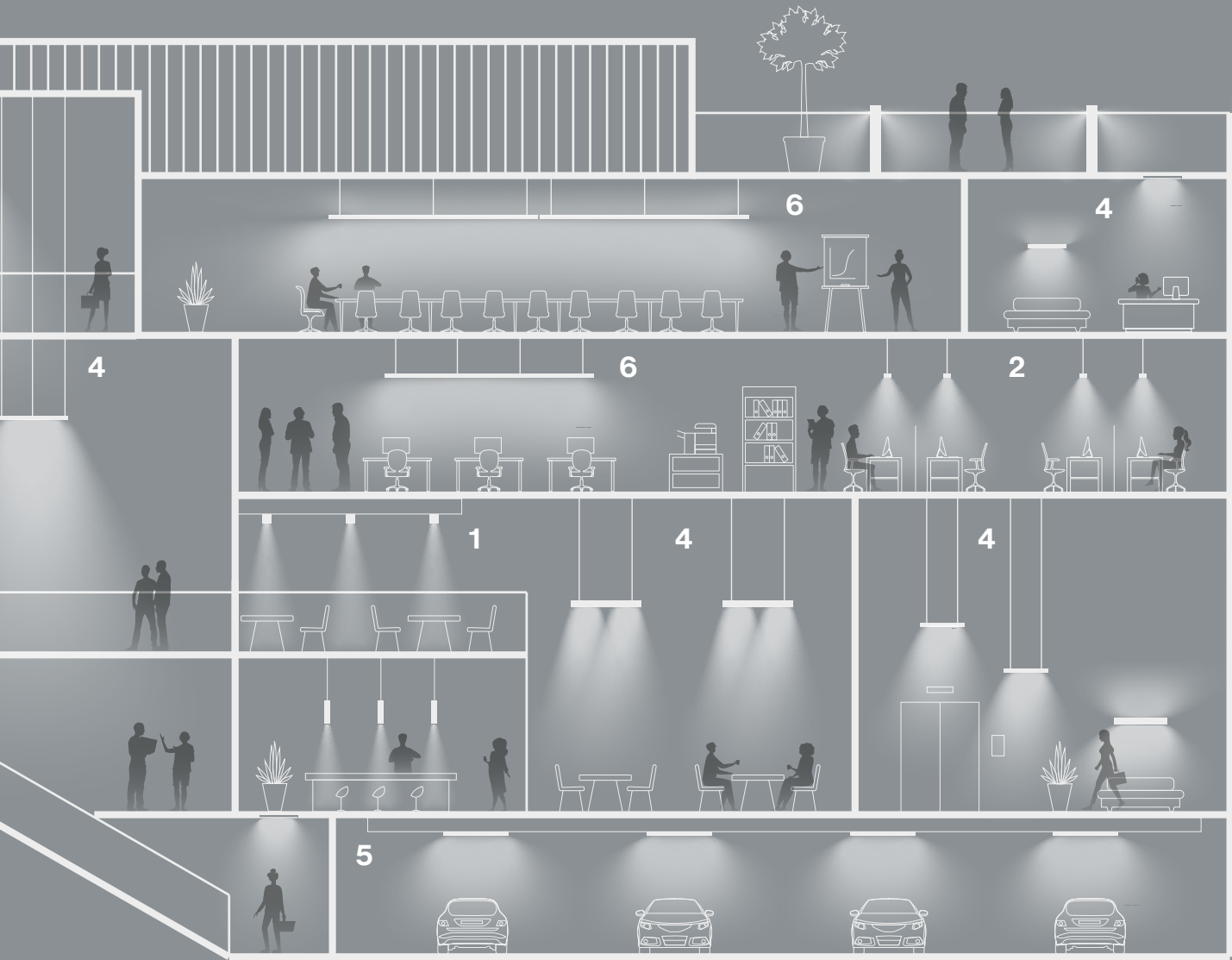

1. narrow spot
15° up to 35°

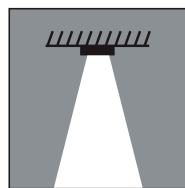

2. medium spot
30° up to 60°

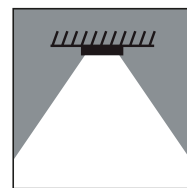

3. flood
60° up to 90°

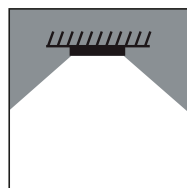

4. wideflood
90° up to 120°

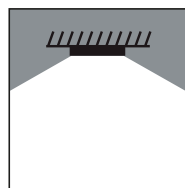

5. superflood
more than 120°

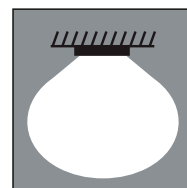

6. frosted



A variety of options

It is possible to personalise the product by choosing between different variations of diffusers and optical systems. Optics systems based on lenses - guarantee many different light distributions.

1. PLX - opal diffuser made of PMMA (polymethyl methacrylate). A smooth structure provides diffused light distribution and is often used in basic lighting fixtures.

2. Micro-PRM - opal diffuser made of PMMA (polymethyl methacrylate). A microprismatic structure provides a narrower distribution with more focused light. Luminaires equipped with such a diffuser are characterised by a lower glare, which makes them perfect for office lighting.

3. Tempered glass and matt tempered glass - most often used in clean luminaires. It increases the mechanical resistance of the luminaire and can be used alone (matt tempered glass) or in combination with Micro-PRM (tempered glass).

4. Laminated glass and matt laminated glass - made of two layers of glass secured with the foil between them, often used in the production of food.

5. PC (polycarbonate) - characterised by high mechanical resistance of the luminaire (IK10) and resistant to high temperatures.

6. LOW UGR louvers - characterised by lower glare factor, which makes them perfect for office lighting.

7. Transparent glass - protects the light sources and increases the degree of tightness of the luminaire. It does not affect the light distribution in such a significant way as matt glass does.

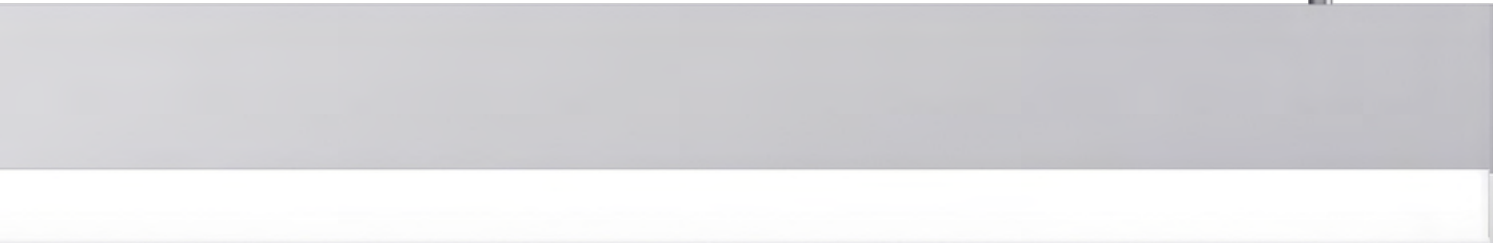

X-Line Pro Compact



1. PLX

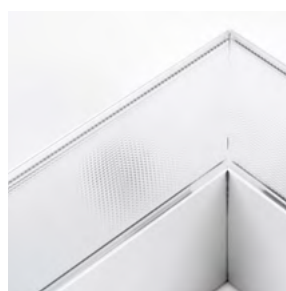

2. Micro-PRM



3. Tempered glass and matt tempered glass



4. Laminated glass and matt laminated glass



5. PC (polycarbonate)



6. LOW UGR louvers



7. Transparent glass



Customised gear

Smart lighting opens up a new range of possibilities for designers. It enhances comfort, adds drama and introduces flexibility by giving users the power to create the lighting conditions they need. By tuning the tone and brightness of light at different time of day it's easier to keep everyone focused and alert. Lighting system can change for every time of the day, or follow the sunrise and sunset on each day. The luminaires can be also equipped with an emergency module that provides the luminaire with the possibility of emergency operation.

Casambi

Casambi is a smart lighting system, that allows a mobile device to communicate directly with a luminaire and luminaires to communicate with each other. It uses a low-power radio communication technology that's built into every modern smartphone, laptop, and tablet. Which makes them ideal tools for controlling lighting, colour, or setting up scenes. It helps bring flexibility and personalisation to designs. By using sensors built into fittings it's also possible to respond to different circumstances and share the data in the cloud.

DALI

DALI is a protocol that enables efficient communication. It works between individual luminaires or groups of luminaires and a control system. It integrates and communicates with other system components such as motion detectors and light sensors, allowing for quick and easy reconfiguration. By use of intelligent LED lighting control, it's possible to save costs associated with lighting, by reducing light intensity in certain working areas which are not currently used or have sufficient daylight.

CASAMBI



 Bluetooth™



CLO ready



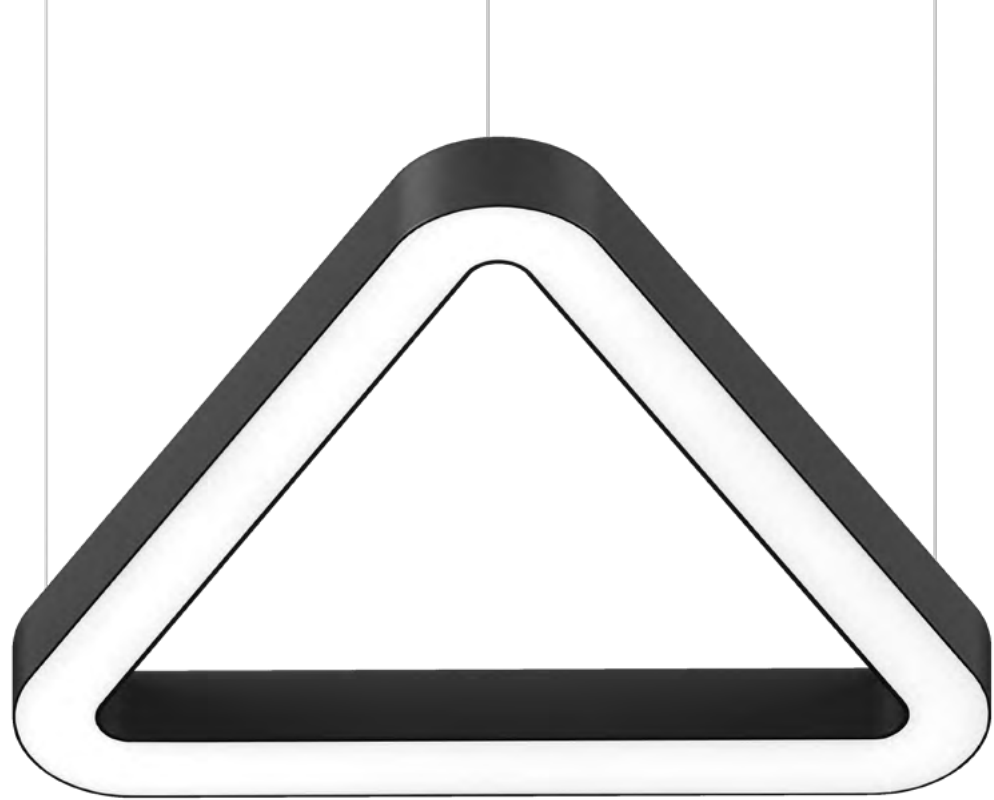

Artshape Three



Customised Body

Variety of shapes

Thanks to the offer of luminaires with diverse shapes, you can mix and match them into unique combinations, as in the case of the Mosaic family.

By choosing architectural luminaires from the Artshape family it's possible to emphasise the character of the space thanks to various shapes. Luminaires in standard versions are available in three sizes, seven different geometric shapes and also in Edge and Full versions.

Customisable dimensions

The products from our offer can be personalised in terms of length, width or diameter, giving you limitless possibilities and allowing you to match the product perfectly to the space.



Mosaic

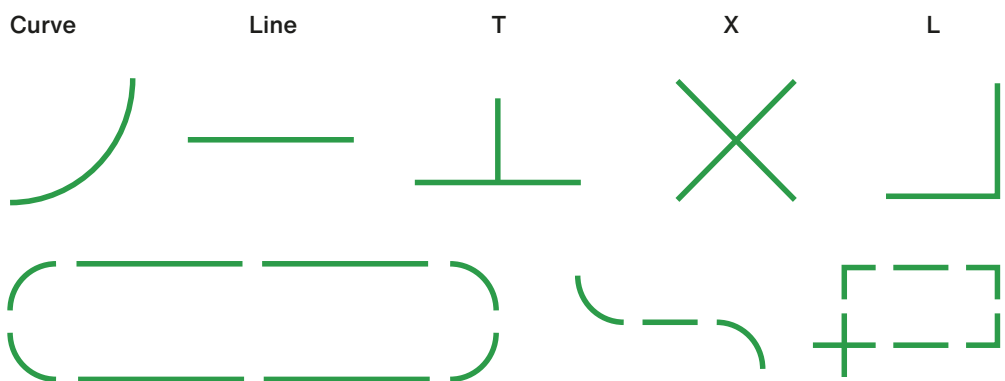

Artshape

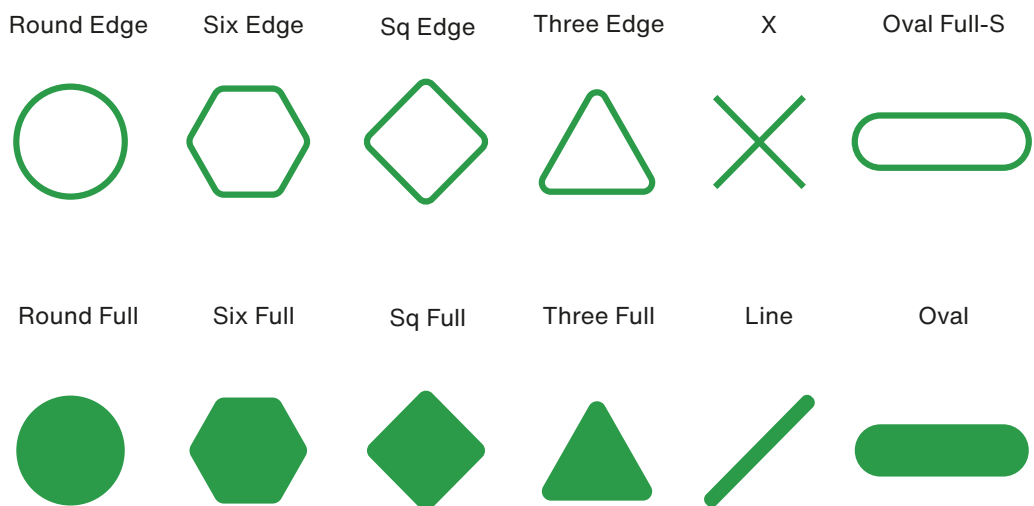

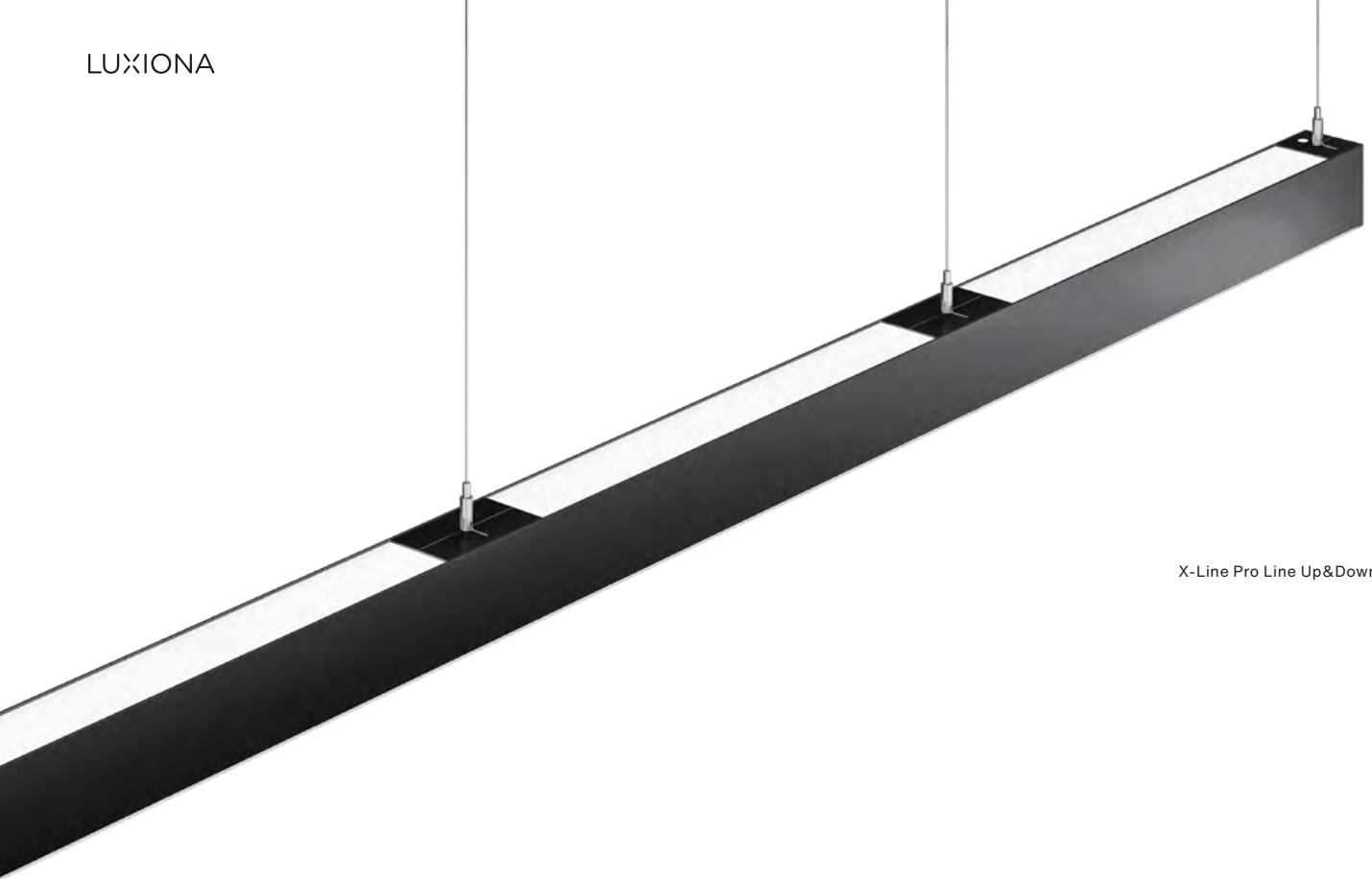

X-Line Pro Line Up&Down

Modular systems

In modern office environments, the ability to quickly and efficiently adapt lighting systems to changes in layout and flexible office workflow is important for maintaining productivity and supporting change and improvement.

Rather than completely overhauling the entire lighting system, it is more practical and cost-effective to simply replace individual modules or add new ones. To achieve such flexibility, lighting systems must be designed with adaptability in mind, and use modular components and support rail systems that allow for easy repositioning of luminaires without the need for tools or complex installation procedures. Self-supporting rail systems, in particular, provide an excellent basis for lighting in office spaces, as they offer maximum flexibility to quickly and smoothly react to changes in layout,

caused by increased or reduced number of workstations, or by the changes in the purpose of how the space is used. Those changes mean that new tasks will be performed in the space and will require a new lighting layout. With modular systems this means that changes can be done flexibly without additional costs of interruptions in a workflow.

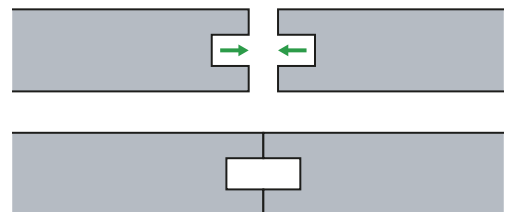



UMCS University, Lublin. Poland



Wtorpol, Skarzysko-Kamienna. Poland 21



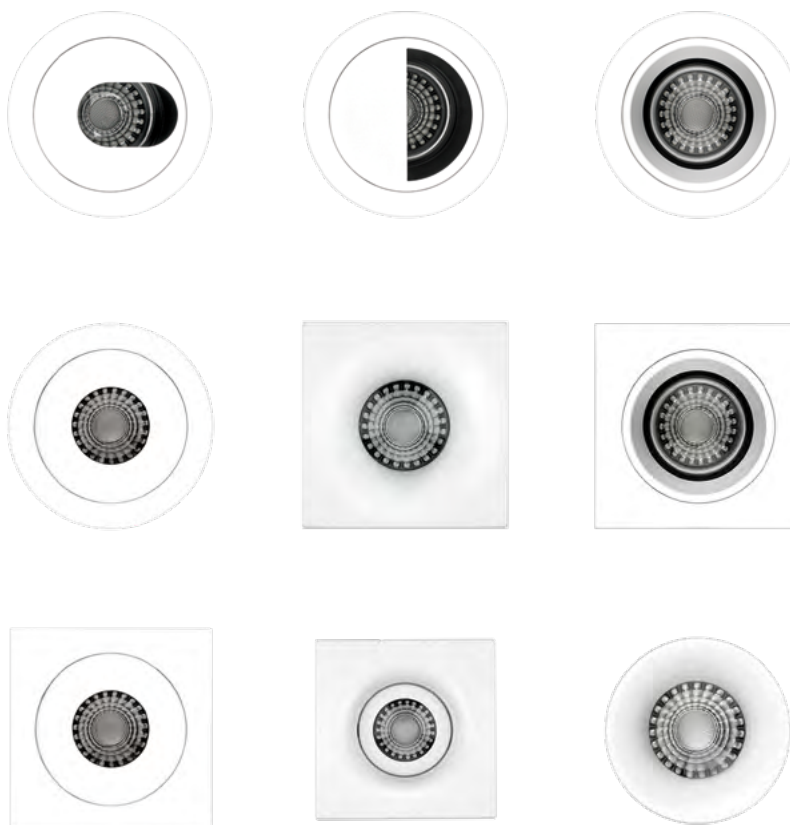

Versatile Modular System

Modular system, that combines light engines, optics, frames, shutters, etc. giving endless combinations.

The system is complemented by different frames that allow the personalisation of the space:

1. Basic series, in square and circular format with customisable secondary reflector, made of plastic material.



2. Soft series, in square or circular format, both fixed and adjustable. Made of aluminium and steel. This series has a trimless circular version.



3. Pinhole series, made of aluminium, the installation frame is complemented with different accessories to generate various light effects.



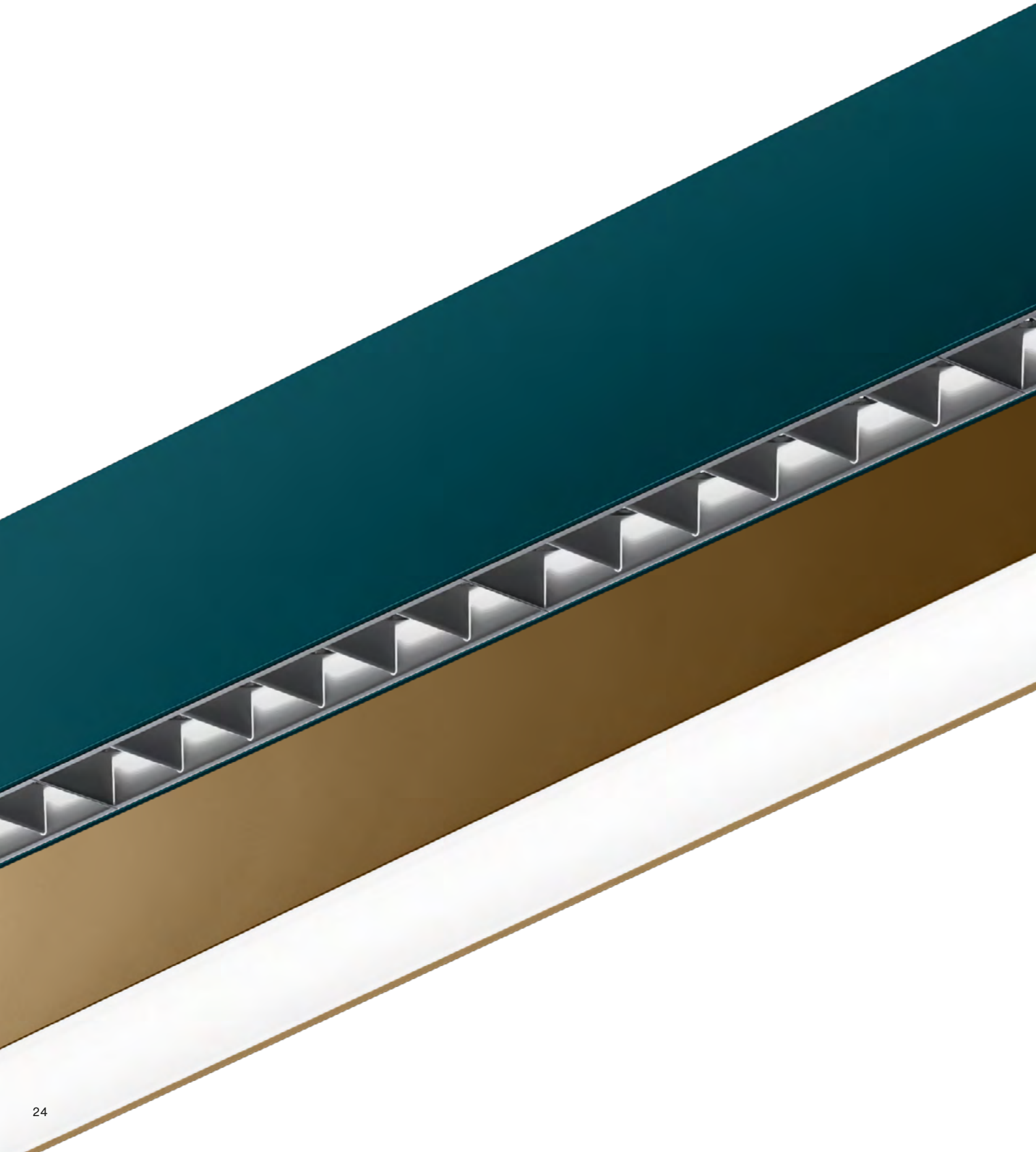

X-Line Slight

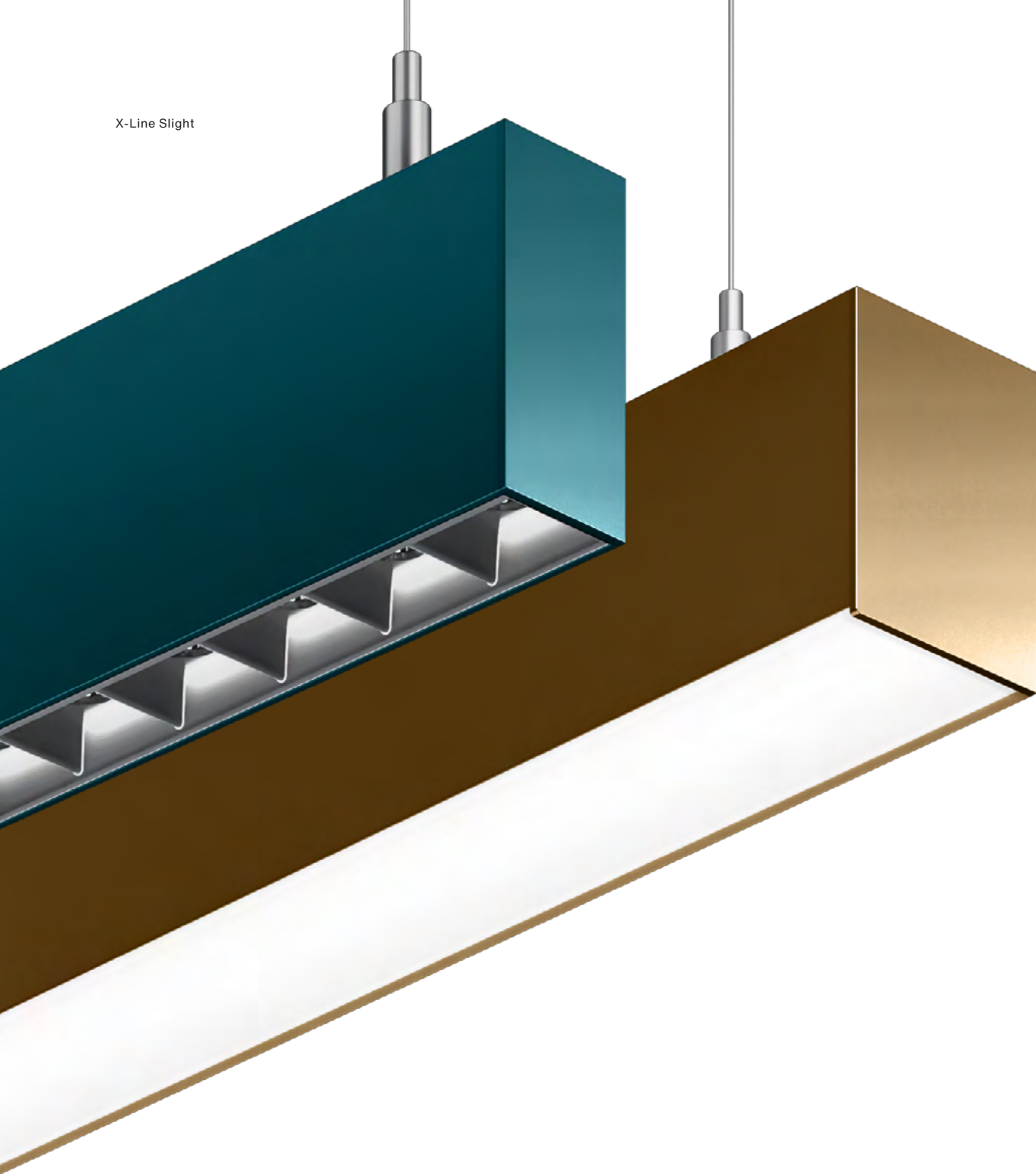

X-Line Pro



Colours speak louder than words

With a variety of colours available in our offer designers gain real freedom in bringing to life their perfect projects.

The possibility of painting some of our luminaires according to the RAL palette is another step toward limitless creativity. While the white luminaire can be easily integrated with the ceiling or walls, sometimes it's necessary to create a visual

diversity between them. The vivid colour of a luminaire can become an eye-catching highlight or an integral part of any space.

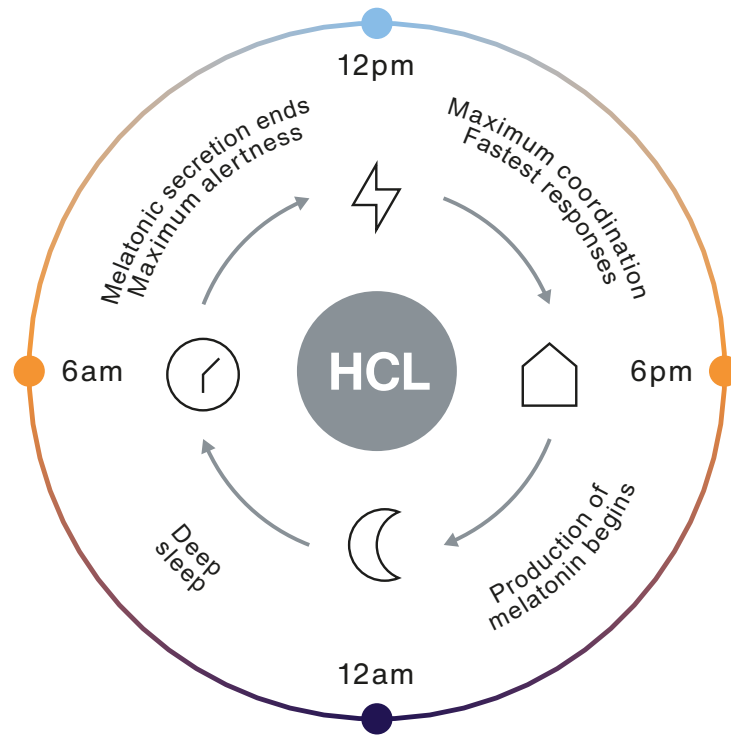

Human Centric Lighting

Powerful tool for helping us stay focused and motivated during our work hours.

Our life cycles are closely linked to the cycles of natural light and darkness. However, we currently spend most of our time indoors, often being subjected to artificial lighting, which alters our natural biorhythms, and therefore our states of alertness and rest. To help us regain this balance we align four dimensions of light: direction, colour, intensity, and time of exposure to create lighting that supports people's well-being throughout the whole day of work.

Human Centric Lighting (HCL) allows us the purposeful, long-term light's impact on our activities and needs. It includes the biological, visual, and emotional impact of natural and artificial light on our organisms. The HCL approach focuses on supporting the body's circadian rhythm, a process that lasts approximately 24 hours.

An effective lighting solution taking into consideration the HCL approach uses the colour and the brightness of the light to imitate the changes natural light undergoes

throughout the day. It allows us to define levels of visual comfort and create the correct relationship between lighting levels and colour temperature better suited to our activities, with the help of technologies such as Tunable White.

The effect is calming and relaxing in the evening and stimulating during the day. Rising the levels of melatonin introduces us to a state of relaxation and helps us improve our rest and sleep patterns. Through the suppression of melatonin, we help increase activation and alertness.



Dawidczyk & Partnerzy, Warsaw. Poland

Lighting your office together with LUXIONA

Providing adequate lighting in the workplace helps to maintain the required light levels and meets all the needs of employees including safety, visual and acoustic comfort.

A lighting solution, with the right colour temperature, intensity, and uniform illumination of the surface favours the symbiosis between the architectural space and its function and the needs of users. It provides the appropriate aesthetic impressions, affects the well-being and physical and mental comfort, which is so important in the workplace. Office

lighting should combine natural sunlight and artificial light. Working in front of a computer is a strain on the eyes. Proper illumination of the environment will minimize contrast, which if too high can cause discomfort while working.



Visual comfort

Our luminaires reflect perfectly the chosen space, complement its character and provide an optimal user experience. Well adapted lighting solution blends into the interior design, subtly enhancing the spaces' character and creating organic an inviting atmosphere.



Acoustic comfort

Acoustic comfort within office spaces is a critical determinant of productivity and well-being, as excessive noise pollution can impair concentration and communication. Implementing acoustic luminaires represents an efficacious strategy to mitigate such disturbances, effectively fostering a quieter and more conducive work environment.



Wellbeing & Productivity

Lighting affects our energy levels and contributes to physical and emotional well-being. Adequate lighting reduces the feeling of sleepiness in the first hours of work. By restoring the natural biorhythm in the workplace, it's possible to affect our productivity and creativity. Flexible light enhances motivation and improves the quality of work and time spent at the office.

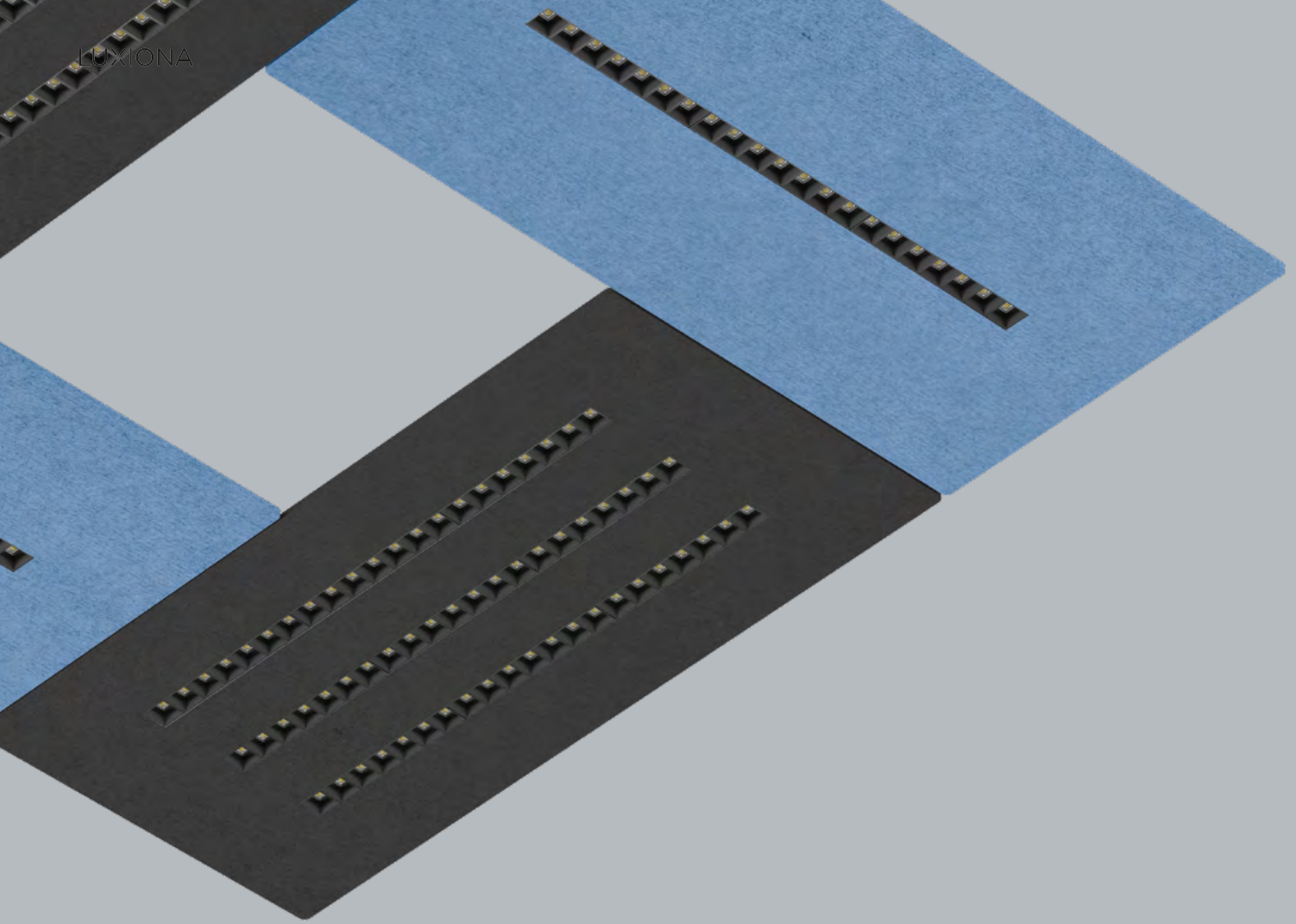

Aribau Sound Absorbent **A**

Sound absorbent solutions

Sound absorbent luminaires: elevating comfort and productivity

Noise pollution, often being a result of open-plan layouts and increased collaborative work settings, stems from conversations, foot traffic, and ambient sounds, disrupting focus, hindering communication, and raising stress levels. This impairs productivity and creative thinking and can even lead to fatigue, burnout, and lower job satisfaction. To reduce these issues, sound absorbent luminaires provide a versatile solution that combines lighting and sound absorption.

Incorporating sound-absorbing materials, these fixtures dampen reverberations and sound wave propagation and enhance speech clarity on top of exceptional lighting parameters and efficiency. Moreover, LUXIONA luminaires offer aesthetic diversity, coming in various designs, sizes, and colours, seamlessly complementing office decor.

Visual and acoustic comfort

Sound Absorbent Luminaires for elevated productivity and well-being

At LUXIONA, we pride ourselves on delivering lighting solutions that not only enhance aesthetics and lighting performance but also address the critical issue of noise pollution. Our latest solutions, sound-absorbent luminaires, represent a holistic approach to improving acoustic quality in various environments.

By incorporating advanced sound-absorbing materials in our luminaires and strategically combining them with other carefully selected technologies, we have created a seamless integration of lighting and acoustic comfort. This combination not only optimizes the visual aspect of spaces but also mitigates the negative effects of noise pollution.

The benefits of our sound-absorbent luminaires extend across diverse settings. In office environments, employees will experience heightened concentration levels and improved well-being, leading to increased productivity and job satisfaction this effects positively the talent retention. Also restaurants and chill-areas will provide enhanced privacy and clarity during conversations, elevating their overall experience and ensuring that customers will come back.

Types of installation of acoustic solutions

In various rooms, depending on their acoustic properties, the materials used, and their intended use, there may be a demand for different types of installation of sound absorbent.

Specifically suspended units are utilized as solitary islands above workstations, it is recommended to install the lumianires as close to the workstations as possible. This positioning allows for more efficient absorption of sound waves generated within the immediate vicinity of the workspace. Moreover, the suspended units should adequately cover the work area.

Suspended units as a complement are recommended to divide the suspended units into smaller, evenly distributed units across the entire ceiling area. By employing smaller units spread across the ceiling, sound absorption is enhanced throughout the space, ensuring a more balanced and consistent reduction of ambient noise.

Rating according to ISO 11654: 1997
Weighted sound absorption coefficient

$a_w=0,85(H)$
Sound absorption class: Class B

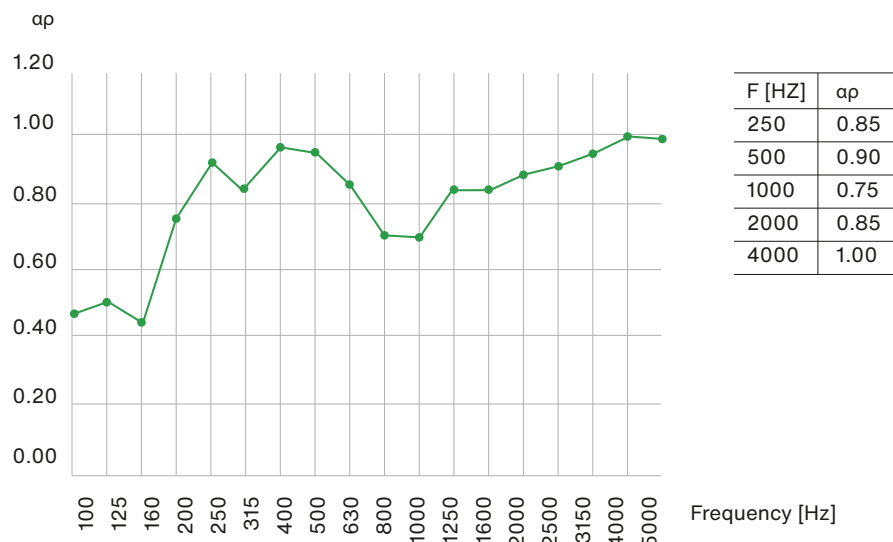

Lighting solutions for every space

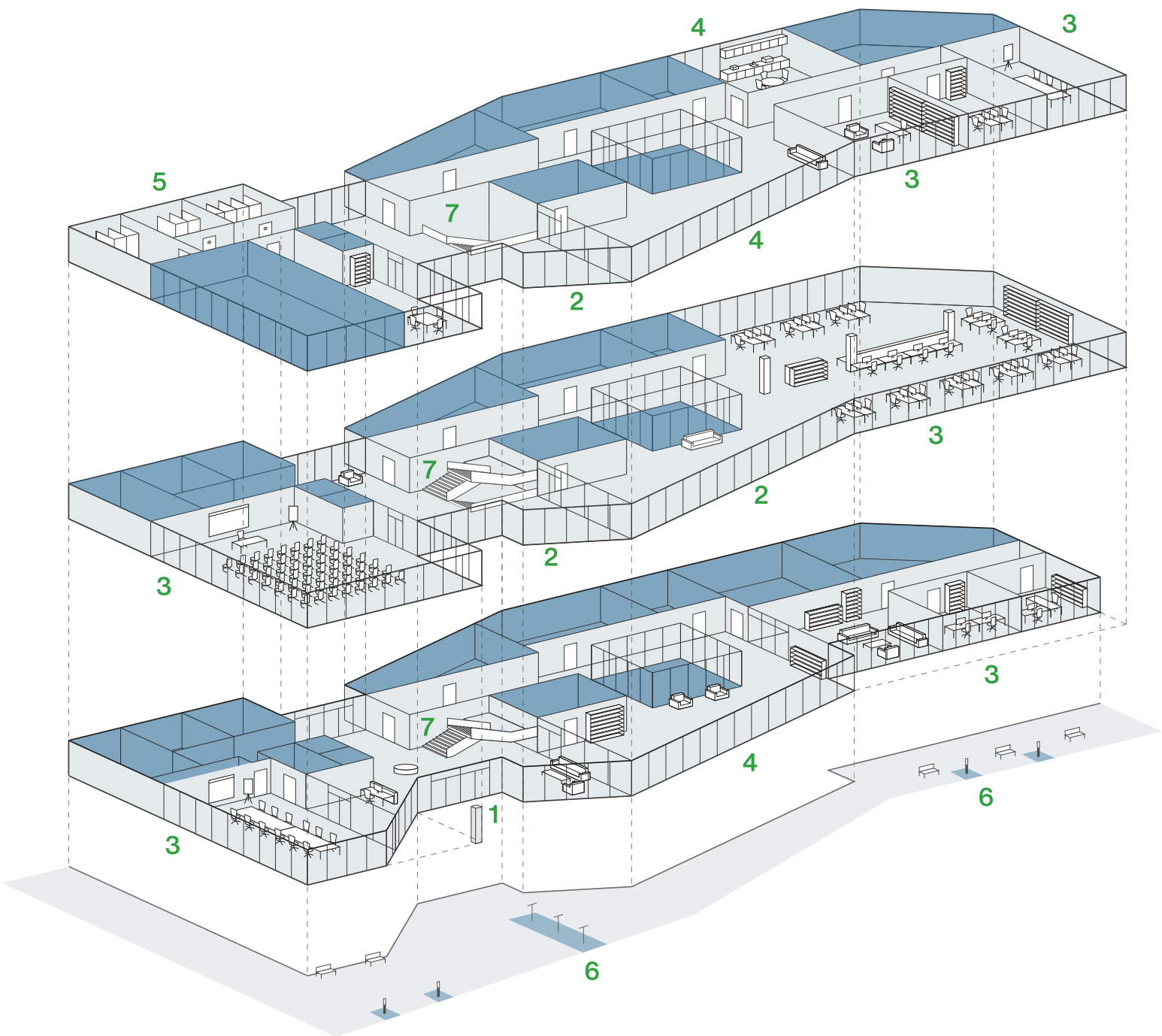

1 Entrance and presentable areas

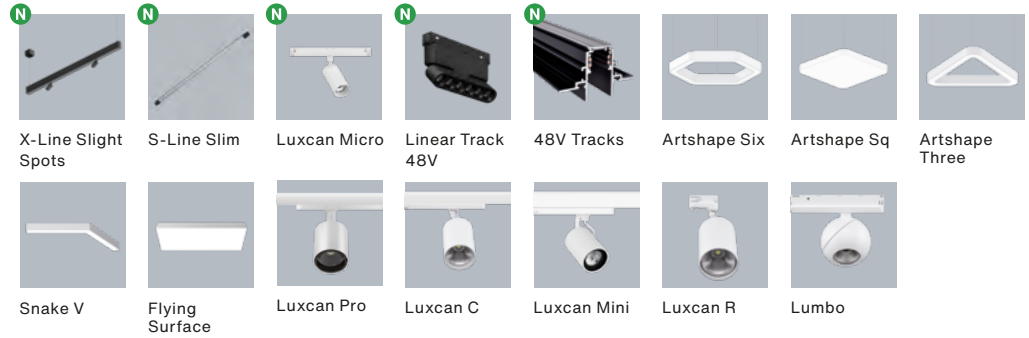

2 Corridors and stairways



3 Conference rooms, classic rooms and open spaces



Special Sound Absorbent Luminaires

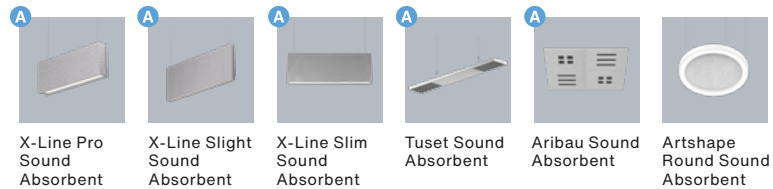

4 Chill areas and meeting points

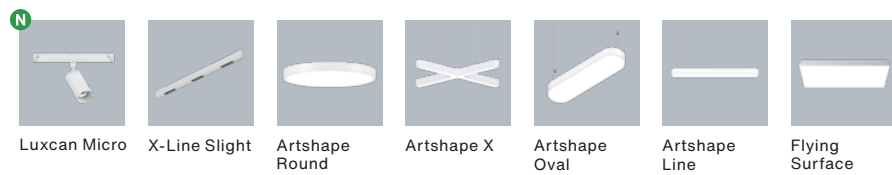

5 Complementary spaces



6 Outdoor lighting

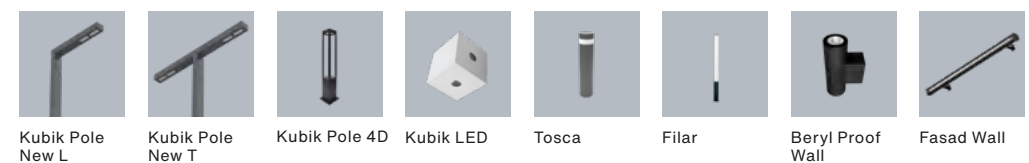

7 Emergency lighting

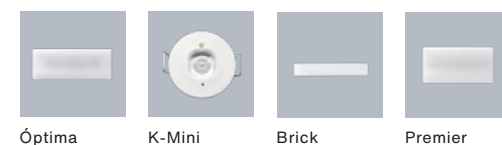

N New product - Check availability
A Sound absorbent



Artshape Six

Entrances and presentable areas

Corridors and stairways

Conference rooms, classic rooms and open spaces

Chill areas and meeting points

Complementary spaces

Outdoor lighting

Emergency lighting



X-Line Slight Spots N

General and accent lighting combined in one solution with a very thin profile. With compact, adjustable projectors that rotate for precise illumination, this system is perfect for highlighting any detail. Available in different versions and finishes.



S-Line Slim N

Endless design possibilities with ultra-slim (Ø30mm) lighting system, with three light module options, 360° rotation allowing for direct or indirect lighting in a variety of shapes, from linear to L, T, and X shapes available in multiple lengths.

Entrances and presentable areas



Artshape Three

Best way to evade boredom. Luminaire combines modern design and functionality with atmospheric character. It allows creating a variety of unconventional accents thanks to the availability of Full and Edge versions.



Artshape Six

Unconventional shape combined with modernistic character. This architectural luminaire from Artshape family perfectly fit in modern and creative spaces giving them an additional boost.



Artshape Sq

A timeless design that provides creative lighting effects with the use of a simple geometrical square shape. With the possibility of painting according to RAL palette, it takes on diverse tasks in various spaces.



Snake V

Versatile lighting with a surprising twist. Luminaire combines comfortable lighting with creative appearance.

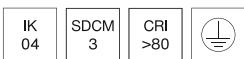

Flying Surface

A visionary eye-catcher. An extraordinary proposal that arose from French designer **Jean Nouvel** and Troll's alliance. A light surface gives the feeling of floating around in space and provides highly even and balanced lighting.

N New product - Check availability

Products represent a selection of lighting solutions. See the complete portfolio of our products at www.luxiona.com







Luxcan Pro

Entrances and presentable areas - continuation

Corridors and stairways

Conference rooms, classic rooms and open spaces

Chill areas and meeting points

Complementary spaces

Outdoor lighting

Emergency lighting



Linear Track 48V N

An advanced low-voltage luminaire system with modular design. The track supports versatile luminaires, allowing tool-free interchangeability. It offers multiple optics, with fixed and adjustable versions (360-degree rotation and 90-degree vertical adjustment).

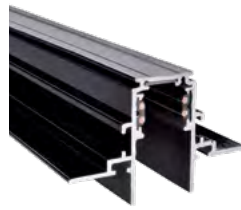

48V Tracks N

A flexible solution offering both aesthetics and functionality. Available in recessed, surface-mounted, or suspended versions, it supports various luminaires for accent and general lighting that can be easily repositioned without tools.



Luxcan Micro N

A compact and versatile range of high-performance luminaires available in 48V track-mounted, suspended, and semi-recessed versions. These minimalist projectors combine powerful, efficient light output with a discreet design with wide range of available versions.

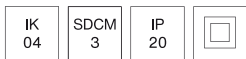

Luxcan Pro

Product for different applications. Various optics, based on lenses, provide a wide range of beams from narrow, through the indirect beam, to the wide beam. The product is available in several colours, with the possibility of ordering a non-standard version.

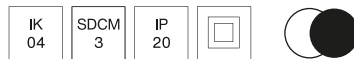

Luxcan C

Combines the most advanced LED light sources with a variety of optics, which allows it to be used as an accent lighting in places that require distinction. Placing the power supply in the adapter allows for a smaller size of the luminaire.



Luxcan Mini

Small but strong. A classic luminaire with an optical system providing a perfect beam of light. Its power supply remains hidden by the rail, which decreases the luminaire's size, implementing the concept of a 'Vision Free System'.

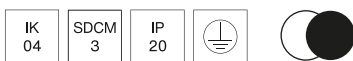

Luxcan R

A cylindrical projector characterised by timeless design that seamlessly fits in any room. Luxcan R combines advanced LED sources with a variety of optics perfect to be used as an accent lighting in spaces that need a nice touch.

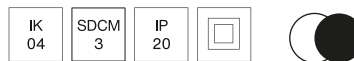

Lumbo

Balance and harmony. Spherical reflector designed for avoiding the visual disproportion. Combines Premium White LED sources with high colour rendering index. Thanks to the 'Total Orientation System' it rotates through 355° or tilts by 90°.





Abertis, Madrid, Spain



Pattari Office Milano, Italy 39



S-Line Slim **N**

Entrances and presentable areas

Corridors and stairways

Conference rooms, classic rooms and open spaces

Chill areas and meeting points

Complementary spaces

Outdoor lighting

Emergency lighting



S-Line Slim N

Endless design possibilities with ultra-slim (Ø30mm) lighting system, with three light module options, 360° rotation allowing for direct or indirect lighting in a variety of shapes, from linear to L, T, and X shapes available in multiple lengths.

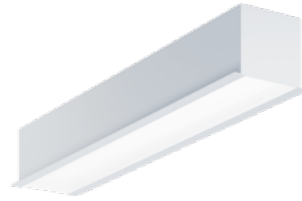

Agat Slim

Versatile lighting, designed to manage light and to create different lighting solutions that focus on getting a comfortable view indoors. Luminaire made from powder-coated steel sheet, perfect for creating long lines.



Patos O

Architectural lighting that embodies an irreproachable style and high-quality lighting parameters. With a circular design and soft light it subtly enhances the space and makes it more warm and welcoming.

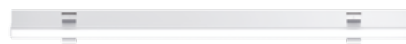

Patos Line

Simple and elegant. Patos is designed for exceptional spaces that need individual modern character. Body made of aluminium profile with a smooth or prismatic diffuser with exceptionally good light transmission coefficient and light diffusion parameters.



Snake V

Versatile lighting with a surprising twist. Luminaire combines comfortable lighting with creative appearance.

N New product - Check availability



Beryl Surface New LED K

Entrances and presentable areas

Corridors and stairways - continuation

Conference rooms, classic rooms and open spaces

Chill areas and meeting points

Complementary spaces

Outdoor lighting

Emergency lighting



Beryl New K

A perfect union between minimalism, elegance and simple shape, that fully integrates with the architectural space. The luminaire has the ability to adjust the optics in two planes (in the vertical axis by 359° and to the left and right 15°).



Beryl New O

Small, yet powerful. Luminaire perfectly aligned with a space's aesthetics, by becoming an integral part of the architecture, with high efficiency and minimum usage. Excellent heat dissipation and large luminous flux for its size.

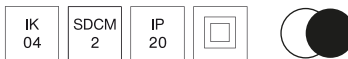

Beryl Surface O

Efficient lighting to light up spaces where architecture and aesthetics are key elements. The effect it leaves on the environment and its visibility for our comfort are hardly noticeable, giving room for great visual ease for its users.

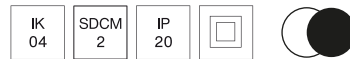

Beryl Surface K

Downlight surface-mounted luminaire unrivaled in combining quality and energy efficiency. The luminaire has the ability to adjust the optics in two planes (in the vertical axis by 359° and to the left and right 15°).

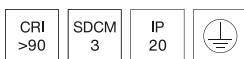

Versatile

Small size customisable downlights that come in different lighting sources and combinable structures that adjust to each environment. Creates minimalist general lighting systems.



Montserrat Roig Library, Sant Feliu de Llobregat. Spain





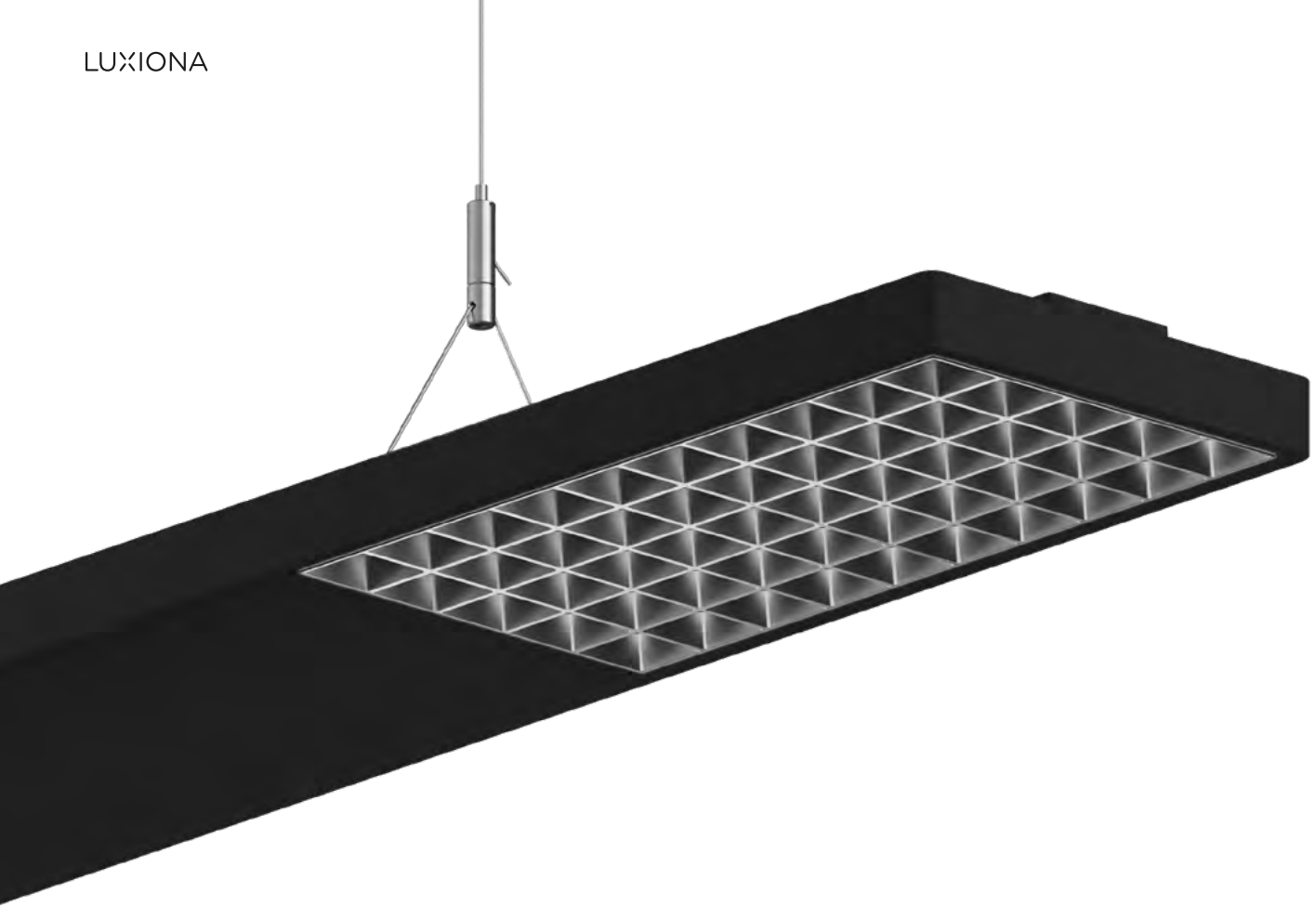

Tuset

Entrances and presentable areas

Corridors and stairways

Conference rooms, classic rooms and open spaces

Chill areas and meeting points

Complementary spaces

Outdoor lighting

Emergency lighting



Backlite V2 N

An efficient and functional solution with a long lifetime, ideal for general lighting in commercial, office and public areas. Zenithic LED light sources and an opal diffuser ensure the perfect distribution of light in the room.

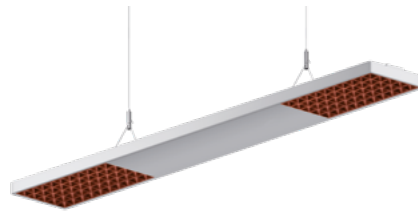

Tuset

Suspended luminaire with a slender aluminium body and anti-glare louvers. Thanks to the possibility of making it in various colors and equipping it with a DIM DALI power supply it will meet the requirements of many various projects.



X-Line Pro

A versatile product from the X-Line family, with a maximally simplified structure, without mounting plates or LED plates, distinguished by aluminium louvers with efficient LED sources.

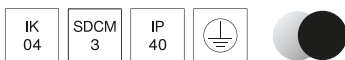

X-Line Slim

Minimalism, effectiveness, and versatility perfectly balanced. Modern linear luminaire with maximum control of luminance. It adjusts to architectural space and gives freedom for design by creating unique long lines of light.



Mosaic

Freedom to create by designing patterns on modular ceilings. The combination of elements: the simple one, the curve, +-shaped, L-shaped, and T-shaped element provides possibilities for unique arrangement, which can be altered anytime.

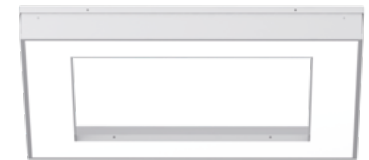

Mosaic Sq

A stylish companion with efficient LED sources. Luminaire, made of steel sheet, with a universal square shape creates the right lighting effect, combined with satisfying standards and guaranteeing the highest level of efficiency.



Europanel

Inconspicuous yet effective. Luminaire with highly efficient LED sources for a wide range of applications. A perfect tool for designers that easily blends with its architectural surroundings.

N New product - Check availability

* Louver colours. Standard body colour: anodised aluminium



Olivia Star Conference Room, Gdansk, Poland



Abertis, Madrid. Spain



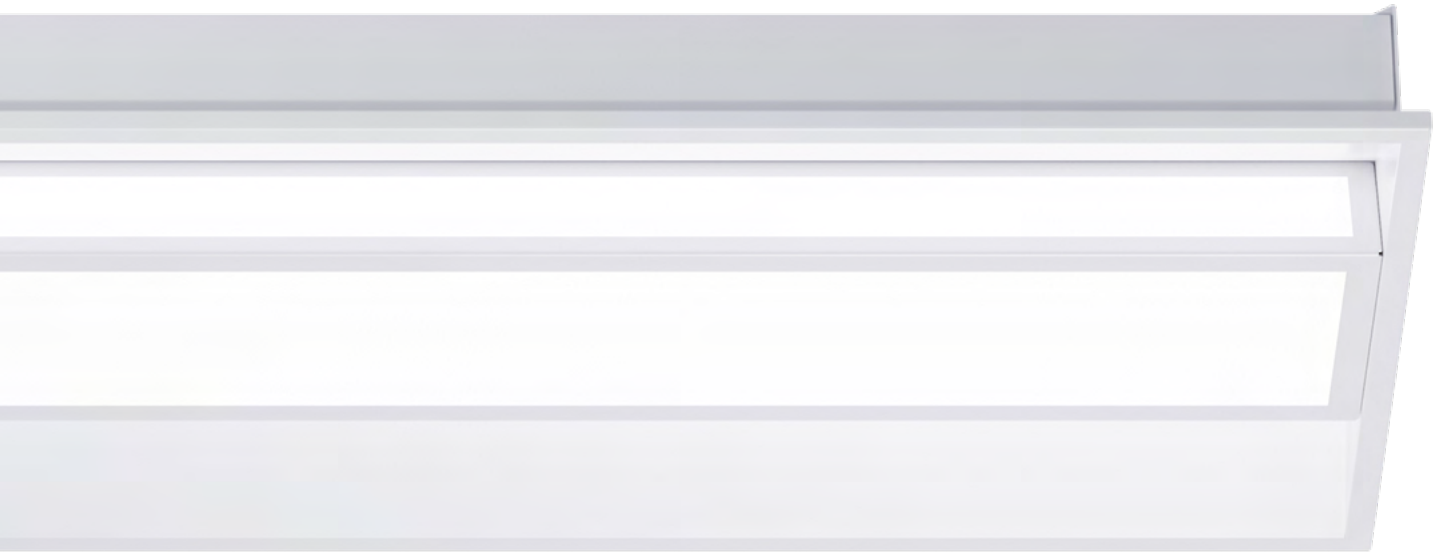

Agat Pos

Entrances and presentable areas

Corridors and stairways

Conference rooms, classic rooms and open spaces - continuation

Chill areas and meeting points

Complementary spaces

Outdoor lighting

Emergency lighting



Domino

Indispensable, equipped with highly efficient LED light sources. It uses an antiglare louvre which reduces glare and directs light precisely, providing perfect light distribution and uniformity as well as welcoming general lighting.



Agat Pos

Discreetly integrates into any architectural space making it recommended choice for various office areas. With efficient LED sources it provides optimal lighting distribution in space for the perfect, extensive illumination.

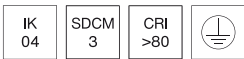

Aruna

The modern fixture equipped with innovative optical design and high-efficiency LED light sources. It provides uniform and pleasant illumination, and its versatile installation options make it the perfect lighting solution for diverse office spaces.

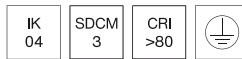
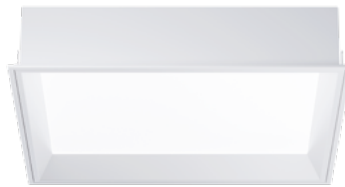

Agat Deco Smooth

Gentle and uniform with mellow light. Made of steel sheet luminaire integrates seamlessly with the overall interior architecture, bringing the depth of the space to life and providing a practical and lasting solutions.

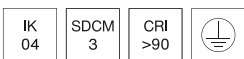

Patos O

Architectural lighting that embodies an irreproachable style and high-quality lighting parameters. With a circular design and soft light it subtly enhances the space and makes it more warm and welcoming.



Snake V

Versatile lighting with a surprising twist. Luminaire combines comfortable lighting with creative appearance.



Intrum Workspace, Málaga. Spain





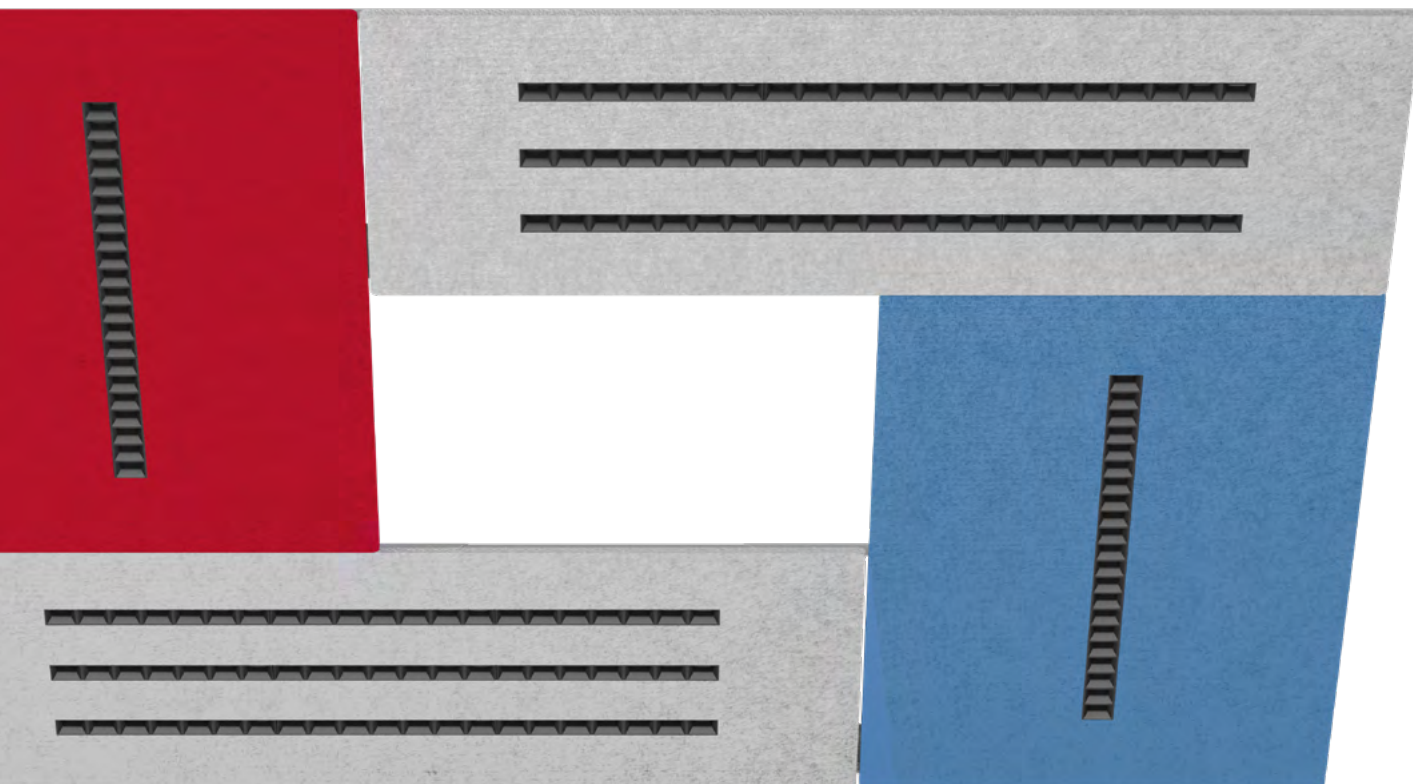

Aribau Sound Absorbent **A**

Entrances and presentable areas

Corridors and stairways

Conference rooms, classic rooms and open spaces: Special Sound Absorbent Luminaires

Chill areas and meeting points

Complementary spaces

Outdoor lighting

Emergency lighting



X-Line Pro Sound Absorbent A

A new, versatile product from the X-Line family, with a maximally simplified structure, without mounting plates or LED plates, distinguished by aluminium louvers with efficient LED sources. Version with sound absorbent accessories.



X-Line Slight Sound Absorbent A

New luminaire with a classic and elegant line. An aluminium profile with a minimised width up to 34mm wide, and a diffuser recessed into the body and aesthetically flushed with the equipment. Version with sound absorbent accessories.



Tuset Sound Absorbent A

Special acoustic version of suspended luminaire with a slender aluminium body and anti-glare louvers. Thanks to the possibility of making it in various colours and equipping it with a DIM DALI power supply it will meet the requirements of many various projects.

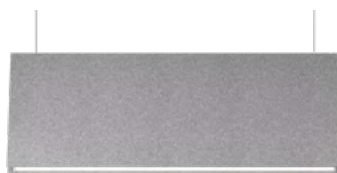

X-Line Slim Sound Absorbent A

Minimalism, effectiveness, and versatility perfectly balanced. Modern linear luminaire with maximum control of luminance. Special Acoustic version with sound absorbent accessories.

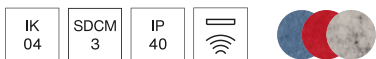
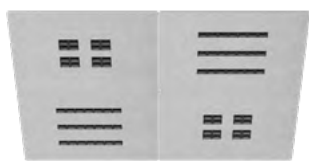

Aribau Sound Absorbent A

Versatile family of pendants, available as single units or as part of complex ceiling systems. With their low-glare louvers and a lower bezel made from acoustic PET felt, Aribau luminaires craft comfortable and tranquil environments in prestigious interiors.



Artshape Round Sound Absorbent A

An architectural luminaire with a round, minimalist shape. The Edge Small version is available with a sound-absorbing accessory made of acoustic PET felt or reindeer moss. Thanks to its acoustic material, it provides acoustic comfort and an aesthetic design, making it ideal for open spaces and reception areas.

A Sound absorbent







Luxcan Micro **N**

Entrances and presentable areas

Corridors and stairways

Conference rooms, classic rooms and open spaces

Chill areas and meeting points

Complementary spaces

Outdoor lighting

Emergency lighting



Luxcan Micro N

A compact and versatile range of high-performance luminaires available in 48V track-mounted, suspended, and semi-recessed versions. These minimalist projectors combine powerful, efficient light output with a discreet design with wide range of available versions.

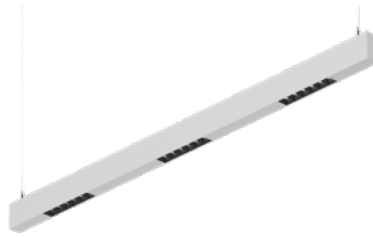

X-Line Slight

Luminaire with a classic and elegant line. An aluminium profile with a minimised width up to 34 mm wide, and a diffuser recessed into the body and aesthetically flushed with the equipment.

Chill areas and meeting points



Artshape Round

Architectural luminaire in round design that allows flexible use, enhances the feeling of a bigger space and gives it a modern and welcoming feeling. Available in Full And Edge versions.



Artshape X

Monotony left behind. A modernistic luminaire tackles the traditional geometry of vertical and horizontal surfaces and produces refreshing lighting effects.

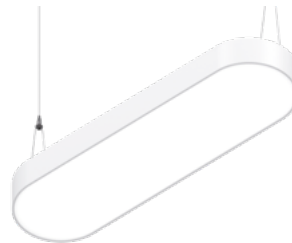

Artshape Oval

With the low profile and elegant appearance the luminaire perfectly meets the challenges of various applications from homogeneous illumination of horizontal spaces to emphasizing highlights such as reception or a meeting point.

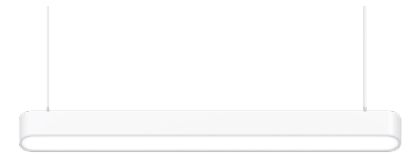

Artshape Line

A straight forward way to beautify architectural projects. A luminaire with a geometrical design that allows creating comfortable atmospheres offering harmony, symmetry, and connection among spaces.

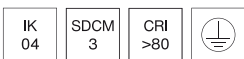

Flying Surface

A visionary eye-catcher. An extraordinary proposal that arose from French designer **Jean Nouvel** and Troll's alliance. A light surface gives the feeling of floating around in space and provides highly even and balanced lighting.

N New product - Check availability



First Workspaces, Madrid, Málaga. Spain

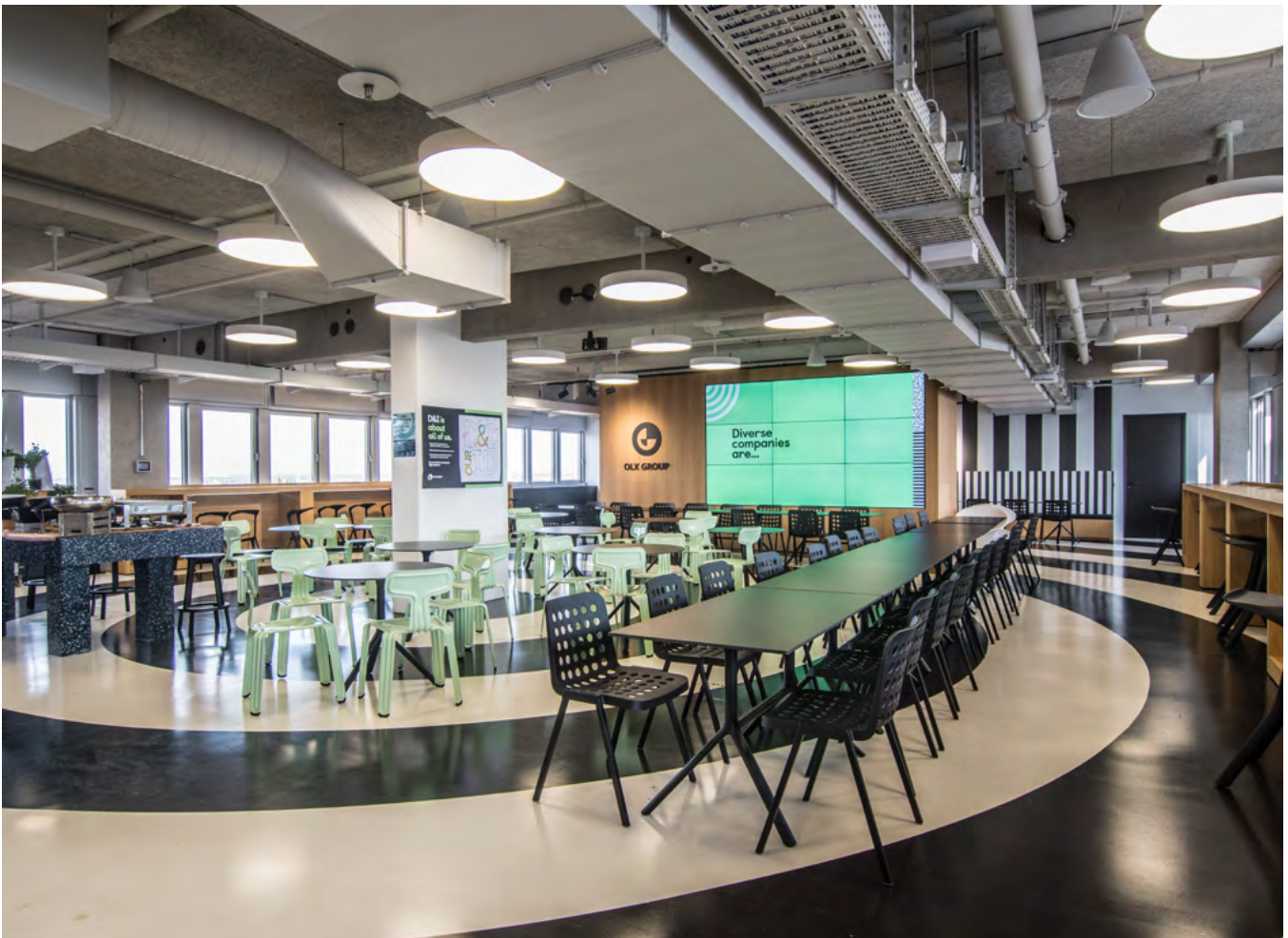





Beryl New LED K

Entrances and presentable areas

Corridors and stairways

Conference rooms, classic rooms and open spaces

Chill areas and meeting points

Complementary spaces

Outdoor lighting

Emergency lighting

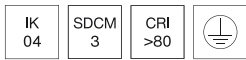

Meteor V2 LED Compact



Surface-mounted fixture with high-efficiency LED sources, ideal for spaces requiring uniform lighting. Sturdy construction and a special diffuser ensure pleasant and effective light in various interiors.



Luxcan Micro



A compact and versatile range of high-performance luminaires available in 48V track-mounted, suspended, and semi-recessed versions. These minimalist projectors combine powerful, efficient light output with a discreet design with wide range of available versions.



Beryl New K

A perfect union between minimalism, elegance and simple shape, that fully integrates with the architectural space. The luminaire has the ability to adjust the optics in two planes (in the vertical axis by 359° and to the left and right 15°).



Beryl New O

Small, yet powerful. Luminaire perfectly aligned with a space's aesthetics, by becoming an integral part of the architecture, with high efficiency and minimum usage. Excellent heat dissipation and large luminous flux for its size.

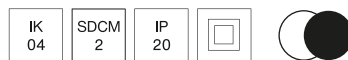

Beryl Surface O

Efficient lighting to light up spaces where architecture and aesthetics are key elements. The effect it leaves on the environment and its visibility for our comfort are hardly noticeable, giving room for great visual ease for its users.

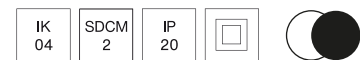

Beryl Surface K

Downlight surface-mounted luminaire unrivaled in combining quality and energy efficiency. The luminaire has the ability to adjust the optics in two planes (in the vertical axis by 359° and to the left and right 15°).

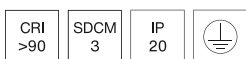

Versatile

Small size customisable downlights that come in different lighting sources and combinable structures that adjust to each environment. Creates minimalist general lighting systems.

New product - Check availability



Kubik Pole L New

Entrances and presentable areas

Corridors and stairways

Conference rooms, classic rooms and open spaces

Chill areas and meeting points

Complementary spaces

Outdoor lighting

Emergency lighting

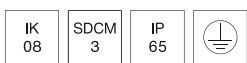

Kubik Pole L New

Outdoor luminaire for assembling on a hardened surface equipped with the highly effective power saving LED sources of the newest generation. The system is designed and optimized for lighting streets, parks, gardens.

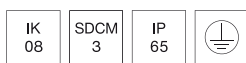

Kubik Pole T New

Geometric T-shaped luminaire. Equipped with highly efficient, energy-saving LED sources with asymmetrical or symmetrical lenses, that provide uniform and functional lighting.

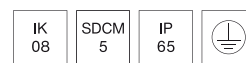

Kubik Pole 4D

Simple geometric form and resistance in all conditions. Luminaire for mounting on a hard surface, equipped with the modern LED sources Luminaire equipped with an optical system for various applications.

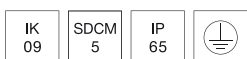

Kubik LED

Ideal for lighting selected outdoor spaces due to its elegant and simple design and its wide range of optical variants. Made in aluminium and powder paint to guarantee maximum resistance to weather conditions.



Tosca

Unobtrusive, elegant, and energy-saving. Designed for installation on a hardened surface, equipped with high-performance, energy-saving LED sources of the latest generation.



Filar

A minimalist design and simple form. Thanks to the combination of the base made of aluminium and the diffuser tube made of acrylic satin, the luminaire perfectly complements surroundings of architectural buildings.



Beryl Proof Wall

An eye-catching accent, cylindrical luminaire that is suitable for mounting on walls, equipped with LED sources with high luminous efficiency. Perfect for decorative or accent lighting of building facades.

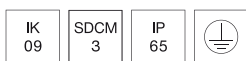

Fasad

Highly effective luminaire resistant to weather conditions. It's best recommended for mounting on walls or top of solid substrates and is perfect accenting architectural objects.





UMCS University, Lublin. Poland

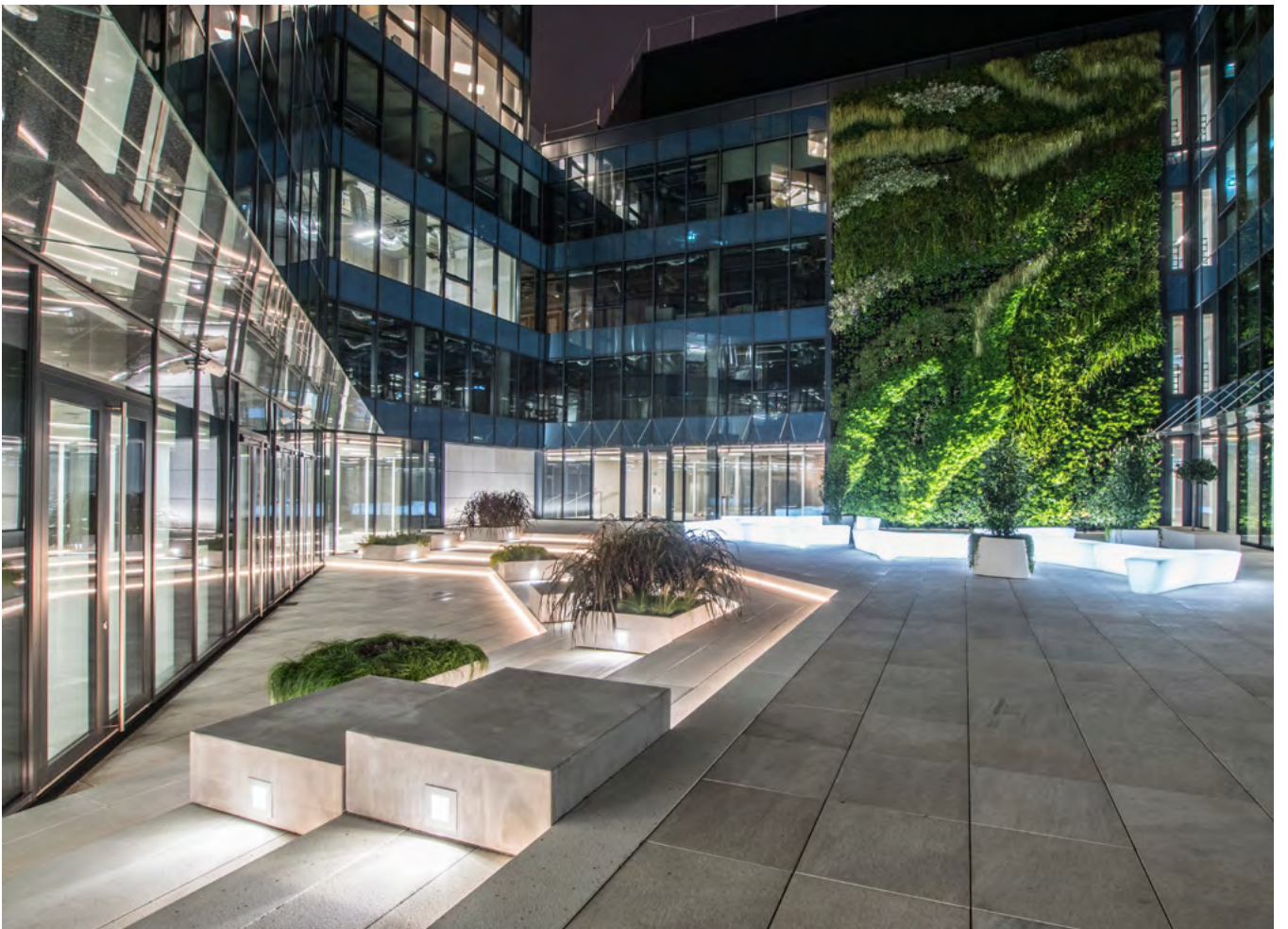

Poseidon Center, Szczecin. Poland 67



Premier

Entrances and presentable areas

Corridors and stairways

Conference rooms, classic rooms and open spaces

Chill areas and meeting points

Complementary spaces

Outdoor lighting

Emergency lighting

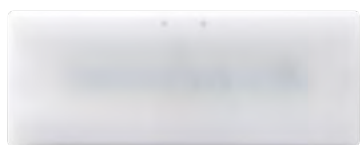

Óptima

Range of emergency luminaires with a minimalist design and maximum functionality available as surface-mounted, recessed, or watertight luminaires. Óptima integrates into the space and meets the technical requirements.



K-Mini

Emergency luminaire designed to minimise the visual impact while meeting with the legal requirements for emergency lighting. Available with optics for anti-panic and evacuation lighting.

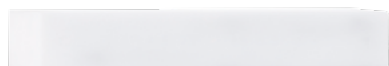

Brick

Stylised design with clean and minimalistic lines. Its small size and geometric features provide the necessary safety with as little impact as possible. Suitable for wall mounting horizontally or vertically.



Premier

Compact design, clean shapes and reduced form. All of that makes Premier able to adapt to the architectural and aesthetic needs of any surroundings with maximum technological benefits.





Center of New Medical Technologies of Pomeranian Medical University, Szczecin. Poland



Selection of luminaires

Technical information summary

More standard versions available at www.luxiona.com

Ask us for other variants different from those shown on our web in terms of light-gear-body.

S-Line Slim

Name	Luminaire luminous flux [lm]	Efficiency [lm/W]	Power of luminaire [W]	Colour temperature [K]	Dimensions [mm]
S-Line Slim Flood	From 1649,7 to 1788	Consult us	18	2700 3000 4000	Ø33 x 1259
	From 2467,6 to 2664,8		26		Ø33 x 859
S-Line Slim Louver	From 1444,4 to 1802,9		18		Ø33 x 1259
	From 2114 to 2631,3		26		Ø33 x 859
S-Line Slim Spot	From 1159,4 to 1588,2		18		Ø33 x 1259
	From 1738,5 to 2382,2		26		Ø33 x 859

Meteor V2 Compact

Name	Luminaire luminous flux [lm]	Efficiency [lm/W]	Power of luminaire [W]	Colour temperature [K]	Dimensions [mm]
Meteor V2 Compact	From 2262.1 to 9464.7	Up to 152.9	From 15.9 to 62.3	3000 4000	620 x 209 x 64
					1203 x 209 x 64
					1460 x 209 x 64

Linear Track 48V

Name	Luminaire luminous flux [lm]	Efficiency [lm/W]	Power of luminaire [W]	Colour temperature [K]	Dimensions [mm]
Linear Track 48V Louver	From 484 to 1477	Consult us	From 8 to 17	2700 3000 4000	120 x 23 x 43
					120 x 23 x 76
					234 x 23 x 43
					234 x 23 x 76
Linear Track 48V PLX					120 x 23 x 43
					234 x 23 x 43

Backlite V2

Name	Luminaire luminous flux [lm]	Efficiency [lm/W]	Power of luminaire [W]	Colour temperature [K]	Dimensions [mm]
Backlite V2 PLX	From 3442 to 5240	Up to 137,9	26 / 33,8 / 39,7	3000	596 x 596 x 34
Backlite V2 MICRO-PRM				4000	
Backlite V2 PLX	4471	Up to 131,5		4000	621 x 621 x 34
Backlite V2 MICRO-PRM					

Luxcan Micro

Name	Luminaire luminous flux [lm]	Efficiency [lm/W]	Power of luminaire [W]	Colour temperature [K]	Dimensions [mm]
Luxcan Micro Semi-Recessed Round	From 405,2 to 533,2	Consult us	5,4	2700	Ø33 x 65
Luxcan Micro Suspended Semi-Recessed				3000	
Luxcan Micro Suspended Track 48V				4000	
Luxcan Track 48V					

X-Line Slight Spots

Name	Luminaire luminous flux [lm]	Efficiency [lm/W]	Power of luminaire [W]	Colour temperature [K]	Dimensions [mm]
X-Line Slight Spots L-Down LED	From 2120/1020 to 7808/1054	Up to 159,2	From 10,8 to 51,1	3000 4000	1162 x 34 x 68
					1723 x 34 x 68
					2284 x 34 x 68
X-Line Slight Spots Low UGR L-Down LED	From 1269/1020 to 3622/1054	Up to 124,5	From 10,8 to 31,4	3000 4000	1200 x 34 x 68
					1600 x 34 x 68
					2000 x 34 x 68
X-Line Slight Spots Up&Down LED	From 9951/1020 to 14151/1054	Up to 155,1	From 10,8 to 95,8	3000 4000	1162 x 34 x 68
					1723 x 34 x 68
					2284 x 34 x 68

Luxcan Pro

Name	Luminaire luminous flux [lm]	Efficiency [lm/W]	Power of luminaire [W]	Colour temperature [K]	Dimensions [mm]
Luxcan Pro	Od 1046,9 do 4004,6	Od 144,1	Od 13,9 do 35	3000 4000	Ø90 x 187

Aribau Sound Absorbent

Name	Luminaire luminous flux [lm]	Efficiency [lm/W]	Power of luminaire [W]	Colour temperature [K]	Dimensions [mm]
Aribau Sound Absorbent	From 1199,8 to 8565,6	Up to 150,8	From 8,4 to 58,5	3000 4000	596 x 596 x 50
					1196 x 296 x 50
					1196 x 596 x 50

Tuset & Tuset Sound Absorbent

Name	Luminaire luminous flux [lm]	Efficiency [lm/W]	Power of luminaire [W]	Colour temperature [K]	Dimensions [mm]
Tuset L-Down LED	From 4268,9 to 4564,4	Up to 154,2	29,6	4000	1198 x 168 x 42
Tuset Up&Down LED	From 6547,6 to 6789,3	Up to 152,6	44,5	4000	1198 x 168 x 42

X-Line Pro & X-Line Pro Sound Absorbent

Name	Luminaire luminous flux [lm]	Efficiency [lm/W]	Power of luminaire [W]	Colour temperature [K]	Dimensions [mm]
X-Line Pro	From 1307,6 to 10173	Up to 169,1	From 13,1 to 75,9	3000 4000	564 x 60 x 70
					1142 x 60 x 70
					844 x 60 x 70
					1684 x 60 x 70
					2244 x 60 x 70
X-Line Pro Line	From 1307,6 to 10173	Up to 169,1	From 13,1 to 75,9	3000 4000	560 x 60 x 70
					1120 x 60 x 70
					840 x 60 x 70
					1680 x 60 x 70
					2240 x 60 x 70

X-Line Slim & X-Line Slim Sound Absorbent

Name	Luminaire luminous flux [lm]	Efficiency [lm/W]	Power of luminaire [W]	Colour temperature [K]	Dimensions [mm]
X-Line Slim L-Down LED	From 1421,4 to 13466,9	Up to 157,5	From 12,4 to 99,1	3000 4000 TW	596 x 596 x 51
					1138 x 48 x 70
					1425 x 48 x 70
					1698 x 48 x 70
					2258 x 48 x 70

X-Line Slight & X-Line Slight Sound Absorbent

Name	Luminaire luminous flux [lm]	Efficiency [lm/W]	Power of luminaire [W]	Colour temperature [K]	Dimensions [mm]
X-Line Slight Low UGR L-Down	From 846,8 to 3624,4	Up to 122,9	From 8 to 31,8	3000 4000	800 x 34 x 68
					1200 x 34 x 68
					1600 x 34 x 68
					2000 x 34 x 68
X-Line Slight L-Down	From 1052,8 to 7807,7	Up to 157	From 8,6 to 51,8	3000 4000	572 x 34 x 68
					1134 x 34 x 68
					1693 x 34 x 68
					2256 x 34 x 68
X-Line Slight Up&Down	From 1586,6 to 14289,4	Up to 154,2	From 12,1 to 97,2	3000 4000	572 x 34 x 68
					1134 x 34 x 68
					1693 x 34 x 68
					2256 x 34 x 68
X-Line Slight Surface Low UGR	From 846,8 to 3624,4	Up to 122,9	From 8 to 31,8	3000 4000	800 x 34 x 68
					1200 x 34 x 68
					1600 x 34 x 68
					2000 x 34 x 68
X-Line Slight Surface	From 1052,8 to 7807,7	Up to 157	From 8,6 to 51,8	3000 4000	572 x 34 x 68
					1134 x 34 x 68
					1693 x 34 x 68
					2256 x 34 x 68
X-Line Slight LED Line	From 1052,8 to 7807,7	Up to 157	From 8,6 to 51,8	3000 4000	570 x 34 x 68
					568 x 34 x 68
					1130 x 34 x 68
					1132 x 34 x 68
					1689 x 34 x 68
					1691 x 34 x 68
					2252 x 34 x 68
2254 x 34 x 68					
X-Line Slight Low UGR LED Line	From 846,8 to 3624,4	Up to 122,9	From 8 to 31,8	3000 4000	796 x 34 x 68
					798 x 34 x 68
					1196 x 34 x 68
					1198 x 34 x 68
					1596 x 34 x 68
					1598 x 34 x 68
					1996 x 34 x 68
1998 x 34 x 68					
X-Line Slight Surface LED Line	From 1052,8 to 7807,7	Up to 157	From 8,6 to 51,8	3000 4000	570 x 34 x 68
					568 x 34 x 68
					1130 x 34 x 68
					1132 x 34 x 68
					1689 x 34 x 68
					1691 x 34 x 68
					2252 x 34 x 68
2254 x 34 x 68					
X-Line Slight Surface Low UGR LED Line	From 846,8 to 3624,4	Up to 122,9	From 8 to 31,8	3000 4000	796 x 34 x 68
					798 x 34 x 68
					1196 x 34 x 68
					1198 x 34 x 68
					1596 x 34 x 68
					1598 x 34 x 68
					1996 x 34 x 68
1998 x 34 x 68					
X-Line Slight Up&Down LED Line	From 1586,6 to 14289,4	Up to 154,2	From 11,7 to 97,2	3000 4000	568 x 34 x 68
					570 x 34 x 68
					1130 x 34 x 68
					1132 x 34 x 68
					1689 x 34 x 68
					1691 x 34 x 68
					2252 x 34 x 68
2254 x 34 x 68					

Artshape

Name	Luminaire luminous flux [lm]	Efficiency [lm/W]	Power of luminaire [W]	Colour temperature [K]	Dimensions [mm]
Artshape Round Small Edge	From 1492 to 23194	Consult us	From 25 to 76	3000 4000 TW	Ø650 x 85
Artshape Round Medium Edge			From 35 to 150		Ø900 x 85
Artshape Round Large Edge			From 50 to 245		Ø1200 x 85
Artshape X			31 & 62		726 x 1000 x 80

Beryl New

Name	Luminaire luminous flux [lm]	Efficiency [lm/W]	Power of luminaire [W]	Colour temperature [K]	Dimensions [mm]
Beryl New LED O-1	From 852 to 4982	Up to 129,6	9,8 & 12,8	3000	Ø100 x 75
Beryl New LED O-2			From 16 to 25,5	4000	Ø165 x 100
Beryl New LED O-3			From 18,4 to 39,3	TW	Ø195 x 110

Snake

Name	Luminaire luminous flux [lm]	Efficiency [lm/W]	Power of luminaire [W]	Colour temperature [K]	Dimensions [mm]
Snake V	From 1683 to 6877	Up to 140,1	From 14,4 to 49,1	3000 4000	590/590 x 63 x 74 1150/1150 x 63 x 74

Mosaic

Name	Luminaire luminous flux [lm]	Efficiency [lm/W]	Power of luminaire [W]	Colour temperature [K]	Dimensions [mm]
Mosaic LED Part1	From 1057 to 5093	Consult us	10 & 13	3000 4000	596 x 95 x 60
Mosaic LED Part2			8 & 14		564 x 157 x 61
Mosaic + LED			19 & 24,7		597 x 597 x 68
Mosaic L LED			10 & 12,6		345 x 345 x 68
Mosaic T LED			11,1 & 19,2		597 x 345 x 68
Mosaic Sq LED			28,2 & 49,1		596 x 596 x 51

Domino

Name	Luminaire luminous flux [lm]	Efficiency [lm/W]	Power of luminaire [W]	Colour temperature [K]	Dimensions [mm]
Domino LOW UGR LED	From 542 to 7423	Up to 146,8	From 12,7 to 50,6	3000 4000	596 x 75 x 50
Domino LOW UGR LED Recessed					596 x 296 x 23
					596 x 596 x 23
					1196 x 296 x 23
					1196 x 75 x 50
	150 x 150 x 43				
	250 x 250 x 43				

Agat

Name	Luminaire luminous flux [lm]	Efficiency [lm/W]	Power of luminaire [W]	Colour temperature [K]	Dimensions [mm]
Agat Pos LED	From 2082 to 7668	Up to 160,4	From 13,9 to 48,8	3000	596 x 596 x 55
Agat LED Deco Smooth				4000	1196 x 296 x 55
				TW	595 x 595 x 120

Versatile

Name	Luminaire luminous flux [lm]	Efficiency [lm/W]	Power of luminaire [W]	Colour temperature [K]	Dimensions [mm]
Versatile 36°	From 834 to 1719	Consult us	9 13 18	3000 4000	H=61,2 H=76,51 H=85,5

Lumbo

Name	Luminaire luminous flux [lm]	Efficiency [lm/W]	Power of luminaire [W]	Colour temperature [K]	Dimensions [mm]
Lumbo	From 1557 to 3248	Up to 127	from 12,8 to 26,4	4000	Ø120 x 148

Luxcan

Name	Luminaire luminous flux [lm]	Efficiency [lm/W]	Power of luminaire [W]	Colour temperature [K]	Dimensions [mm]
Luxcan C 15° CRI>80	From 1430 to 3602	Up to 140,9	12,8 18,8 26,4	3000 4000	Ø85 x 205
Luxcan C 15° CRI>90					
Luxcan C 40° CRI>80					
Luxcan C 40° CRI>90					
Luxcan C 60° CRI>80					
Luxcan C 60° CRI>90	From 1611 to 4241	Up to 129,2	From 12,8 to 33,1	4000	Ø108 x 210
Luxcan R 13°					
Luxcan R 36°					
Luxcan R 60°					

Patos

Name	Luminaire luminous flux [lm]	Efficiency [lm/W]	Power of luminaire [W]	Colour temperature [K]	Dimensions [mm]
Patos-Line	From 899 to 14196	Up to 129,3	From 9 to 35,3	3000 4000 TW	566 x 77 x 81
					1126 x 77 x 81
					1406 x 77 x 81
					1686 x 77 x 81
Patos O30			From 13 to 169		Ø324 x 150
Patos O45					Ø472 x 150
Patos O65					Ø672 x 150
Patos O80 LED					Ø822 x 164
Patos O100 LED					Ø1022 x 164
Patos O120 LED					Ø1222 x 164

Beryl Proof Wall

Name	Luminaire luminous flux [lm]	Efficiency [lm/W]	Power of luminaire [W]	Colour temperature [K]	Dimensions [mm]
Beryl Proof Wall LED Up&Down Narrow	From 1110 to 3959	Up to 168,9	From 8,9 to 25,2	3000 4000	210 x 120 x 370
Beryl Proof Wall LED Up&Down Medium					
Beryl Proof Wall LED Up&Down Wide					
Beryl Proof Wall LED Up Or Down Narrow					
Beryl Proof Wall LED Up Or Down Medium					
Beryl Proof Wall LED Up Or Down Wide					

Fasad Wall

Name	Luminaire luminous flux [lm]	Efficiency [lm/W]	Power of luminaire [W]	Colour temperature [K]	Dimensions [mm]
Fasad Wall LED Flood	From 572 to 4285	Up to 173,5	From 4 to 24,7	3000 4000	364 x 62 x 114
Fasad Wall LED Medium					619 x 62 x 114
Fasad Wall LED Narrow					1180 x 62 x 114

Tosca

Name	Luminaire luminous flux [lm]	Efficiency [lm/W]	Power of luminaire [W]	Colour temperature [K]	Dimensions [mm]
Tosca LED 300	From 1258 to 1339	Consult us	15	3000 4000	Ø210 x 300
Tosca LED 600					Ø210 x 600
Tosca LED 900					Ø210 x 900

Filar

Name	Luminaire luminous flux [lm]	Efficiency [lm/W]	Power of luminaire [W]	Colour temperature [K]	Dimensions [mm]
Filar LED	From 2933 to 5867	Consult us	63 & 125	4000	300 x 300 x 2545 300 x 300 x 3045

Kubik

Name	Luminaire luminous flux [lm]	Efficiency [lm/W]	Power of luminaire [W]	Colour temperature [K]	Dimensions [mm]
Kubik Pole New L	From 5183,8 to 11522,6	Up to 146,2	From 39,4 to 78,8	3000 4000	850 x 120 x 3000
					850 x 120 x 4000
					850 x 120 x 5000
					850 x 120 x 6000
Kubik Pole New T	From 10367,7 to 23045,1	Up to 146,2	From 78,8 to 157,7	3000 4000	1620 x 120 x 3000
					1620 x 120 x 4000
					1620 x 120 x 5000
					1620 x 120 x 6000
Kubik Pole 4D	From 2411 to 5037	Up to 140,3	18,4 25,4 39,3	4000	220 x 220 x 1100
					220 x 220 x 3000
Kubik LED 1x1,7W 24°	From 103 to 1062	Consult us	3	3000 4000 6500	100 x 100 x 94
Kubik LED 1x1,7W 5°-21°			3		100 x 100 x 94
Kubik LED 1x2,4W 24°			4		100 x 100 x 94
Kubik LED 1x2,4W 5°-21°			4		100 x 100 x 94
Kubik LED 1x7,2W 24°			9		150 x 150 x 135
Kubik LED 1x7,2W 5°-21°			9		150 x 150 x 135
Kubik LED 2x1,7W 24°			5		100 x 100 x 94
Kubik LED 2x1,7W 5°-21°			5		100 x 100 x 94
Kubik LED 2x2,4W 24°			7		100 x 100 x 94
Kubik LED 2x2,4W 5°-21°			7		100 x 100 x 94
Kubik LED 2x7,2W 5°-21°			18		150 x 150 x 135
Kubik LED 3x1,7W 24°			7		100 x 100 x 94
Kubik LED 3x1,7W 5°-21°			7		100 x 100 x 94
Kubik LED 3x2,4W 24°			9		100 x 100 x 94
Kubik LED 3x2,4W 5°-21°			9		100 x 100 x 94
Kubik LED 4x1,7W 24°			10		100 x 100 x 94
Kubik LED 4x1,7W 5°-21°			10		100 x 100 x 94

Emergency lighting

Óptima

Name	Luminaire luminous flux [lm]	Efficiency [lm/W]	Power of luminaire [W]	Colour temperature [K]	Dimensions [mm]
Óptima ST 1H NP	From 60 to 500	-	1,01	5000	121 x 315 x 39
Óptima ST 2H NP			1,01		
Óptima ST 3H NP			1,01		
Óptima ST 1H P			1,65 - 5,63		
Óptima ST 2H P			1,65 - 5,63		
Óptima ST 3H P			1,65 - 5,63		

1H, 2H, 3H - autonomy, NP - operation mode (non maintained), P - operation mode (maintained), ST - type of emergency module (autotest)

K-Mini

Name	Luminaire luminous flux [lm]	Efficiency [lm/W]	Power of luminaire [W]	Colour temperature [K]	Dimensions [mm]
K-Mini 1H NP AP	From 120 to 390	-	-	5000	Ø40 x 23
K-Mini 1H NP EV					
K-Mini 1H NP AP					
K-Mini 1H NP EV					

1H - autonomy, NP - operation mode (non maintained), AP - optics for anti-panic and lighting, EV - optics for evacuation lighting

Premier

Name	Luminaire luminous flux [lm]	Efficiency [lm/W]	Power of luminaire [W]	Colour temperature [K]	Dimensions [mm]
Premier ST 1H NP	From 60 to 500	-	1,01	5000	121 x 239 x 39
Premier ST 2H NP			1,01		
Premier ST 3H NP			1,01		
Premier ST 1H P			From 2 to 5,63		
Premier ST 2H P			2,58 & 3,59		
Premier ST 3H P			2		

1H, 2H, 3H - autonomy, NP - operation mode (non maintained), P - operation mode (maintained), ST - type of emergency module (autotest)

Brick

Name	Luminaire luminous flux [lm]	Efficiency [lm/W]	Power of luminaire [W]	Colour temperature [K]	Dimensions [mm]
Brick ST 1H NP	From 60 to 300	-	0,23 & 1,01	5000	45 x 202 x 45
Brick ST 2H NP			1,01		
Brick ST 3H NP			1,01		
Brick ST 1H P			From 1,21 to 2,51		
Brick ST 2H P			2 & 2,58		
Brick ST 3H P			2		

1H, 2H, 3H - autonomy, NP - operation mode (non maintained), P - operation mode (maintained), ST - type of emergency module (autotest)

LUXIONA worldwide



Commercial offices:

Spain, Poland, France, Italy,
Germany

Logistics centre:

Spain

Production:

Poland / Spain (emergency)

LUXIONA

LUXIONA Headquarters

C/ Diputació, 180, 4A
08011 Barcelona
Spain
+34 938 466 909
info@luxiona.com

Spain

C/ Diputació, 180, 4A
08011 Barcelona
Spain
+34 938 466 909
info@luxiona.com

Germany

Berlin Leuchtenfabrik,
Haus A / 1. Etage
Edisonstr. 63
12459 Berlin, Germany
+49 3040 535 600
info@luxiona.de

France

7 Rue Colonel Chambonnet
69500 Bron
France
+33 472 146 666
info.france@luxiona.com

Marketing

marketing@luxiona.com

luxiona.com

support@luxiona.com

Poland

ul. Komitetu Obrony Robotników 48
02-146 Warszawa
Poland
+48 22 721 72 72
info.poland@luxiona.com

Italy

Via Luigi Cadamosto 4
26900 Lodi (LO)
Italy
+39 0 298 274 010
info.italy@luxiona.com

Export

Export Department
+48 505 695 638
customer.care@luxiona.com

Purchasing

globalpurchasing@luxiona.com

[Linkedin.com/company/luxiona](https://www.linkedin.com/company/luxiona)
 [Facebook.com/luxionagroup](https://www.facebook.com/luxionagroup)
 [Instagram.com/luxionagroup](https://www.instagram.com/luxionagroup)
 [YouTube: LUXIONA Group](https://www.youtube.com/LUXIONA%20Group)



